

XHSm centrifugal pump Self-priming

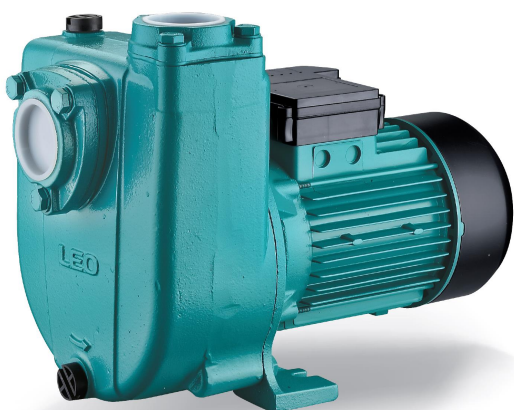

Application

- Transfer of clear water or other liquids chemically and physically comparable to water
- Suitable for pumping water in a lake, river, well
- Industry and irrigation

Pompe

- Special anti-rust treatment (cataphoresis) for the cast iron pump body and the support
- AISI 304 stainless steel shaft
- Maximum liquid temperature: +40°C
- Maximum suction height: 8 m

Moteur

- Integrated thermal protection for single-phase motors
- Insulation class: F
- Protection class: IPX4
- Maximum ambient temperature: +40°C

Identification codes

XHS m 1500

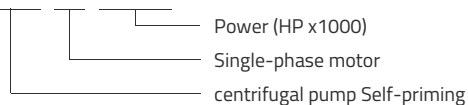

Technical data

MODEL	kW	Q (m³/h)										
		0	2.1	4.5	6.6	8.1	10.2	12	14.1	16.2	19.8	
		Q (l/min)										
		0	35	75	110	135	170	200	235	270	330	
XHSm1500	1.1	15	14	12.5	11	10	8.5	7	5	2.5		
XHSm2000	1.5	20.5	19	17.5	16	15	13.5	12	10	7.5	2.5	

Dimensions

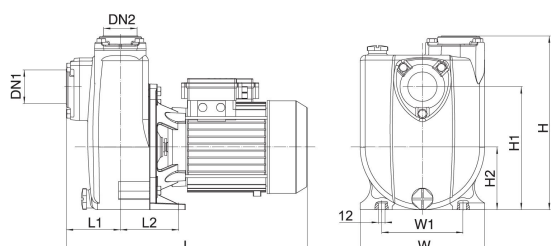

MODEL	DN1	DN2	L	W	H	L1	L2	W1	H1	H2
XHSm1500	2	2	430	222	308	96.5	104	145	218	111
XHSm2000	2	2	430	222	308	96.5	104	145	218	111

Hydraulic performance

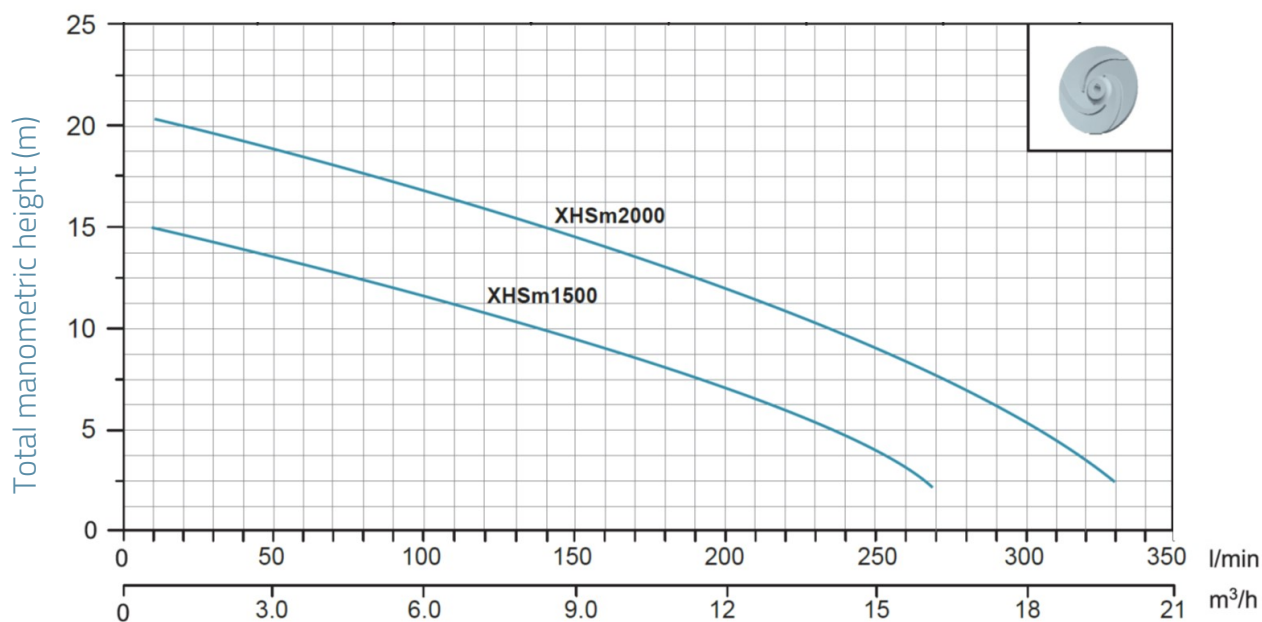

Exploded view

No.	Type	Materials
1	Fan cover	08F steel
2	Fan	polypropylene
3	Rear cover	cast aluminum ZL102
4	Rotor	
5	Bearing	
6	Stator	
7	Lantern	cast iron HT200
8	Mechanical seal	carbon / ceramic
9	Impeller	cast iron HT200
10	Pump body	cast iron HT200
11	Inlet fitting	cast iron HT200
12	Non-return valve	nitrile rubber (NBR)
13	Capacitor	

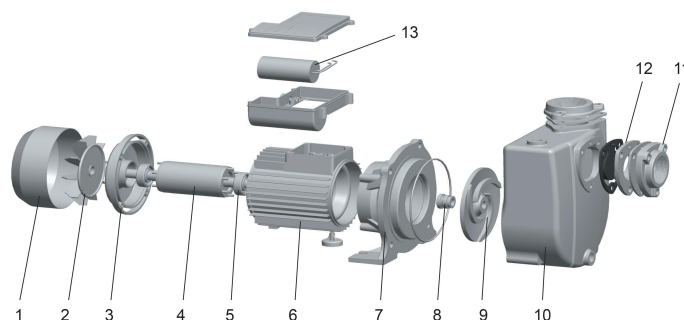

Packaging

MODEL	Weight (kg)	Length L (mm)	Width W (mm)	Height H (mm)
XHSm1500	34.5	475	280	380
XHSm2000	36.5	475	280	380

