

Scope of Performance LVS (R)

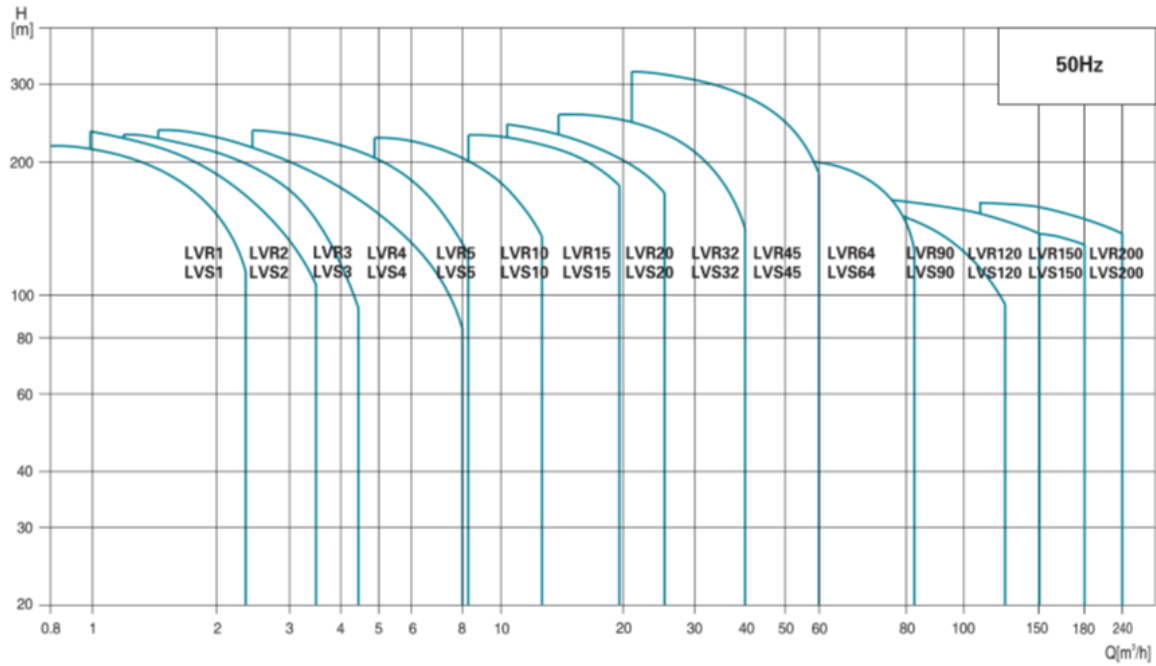

Product Range

MODEL	LVR(S)1	LVR(S)2	LVR(S)3	LVR(S)4	LVR(S)5	LVR(S)10	LVR(S)15	LVR(S)20	LVR(S)32	LVR(S)45	LVR(S)64	LVR(S)90	LVR(S)120	LVR(S)150	LVR(S)200
DESCRIPTION	LVR(S)1	LVR(S)2	LVR(S)3	LVR(S)4	LVR(S)5	LVR(S)10	LVR(S)15	LVR(S)20	LVR(S)32	LVR(S)45	LVR(S)64	LVR(S)90	LVR(S)120	LVR(S)150	LVR(S)200
Rated flow [m³/h]	1	2	3	4	5	10	15	20	32	45	64	90	120	150	200
Flow range [m³/h]	0.7-2.4	1.0-3.5	1.2-4.5	1.5-8	2.5-8.5	5-13	8-23	10.5-29	15-40	22-58	30-85	45-120	60-150	80-180	100-240
Max. pressure [bar]	22	23	24	21	24	22	23	25	28	33	22	20	16	16	16
Motor power [kW]	0.37-2.2	0.37-3	0.37-3	0.37-4	0.37-4	1.1-7.5	1.1-15	1.1-18.5	1.5-30	3-45	4-45	5.5-45	11-75	11-75	18.5-110
Temperature Range [°C]	-20°C--+120°C (Note: Both the Max. permissible pressure and liquid temperature range refer to the pump capacity.)														
Max. pump efficiency [%]	45	46	55	59	60	65	70	72	78	79	80	81	74	73	79
Pipe connection-LVR															
Oval flange	G1	G1	G1	G1 1/4	G1 1/4	-	-	-	-	-	-	-	-	-	-
DIN flange	DN25	DN25	DN25	DN32	DN32	DN40	DN50	DN50	DN65	DN80	DN100	DN100	DN125	DN125	DN150
Pipe connection-LVS															
Oval flange	-	-	-	-	-	-	-	-	-	-	-	-	-	-	-
DIN flange	DN32	DN32	DN32	DN32	DN32	DN40	DN50	DN50	DN65	DN80	DN100	DN100	DN125	DN125	DN150
Clamp connector	φ42	φ42	φ42	φ42	φ42	-	-	-	-	-	-	-	-	-	-
Threaded connector	R ₂ 1 1/4	R ₂ 1 1/4	R ₂ 1 1/4	R ₂ 1 1/4	R ₂ 1 1/4	-	-	-	-	-	-	-	-	-	-

Ambient Temperature

An ambient temperature of over 40 ° C or an installation at an altitude above 1000 meters above sea level requires an oversized motor. Due to low air density and poor cooling, the output power P_2 decreases, as shown in the table below:

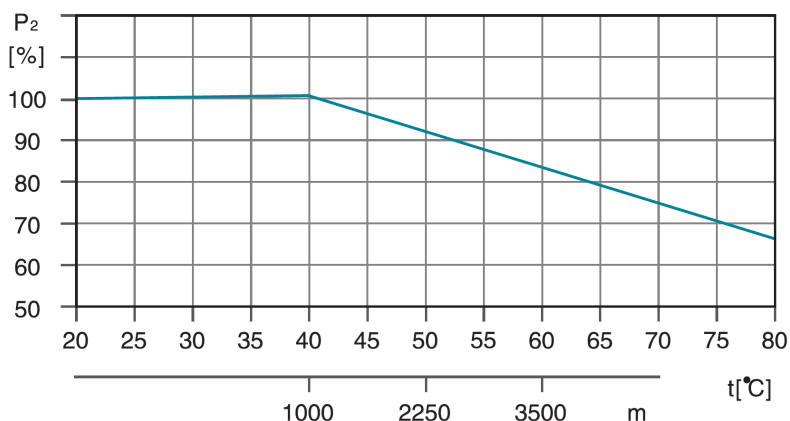

For example, when the pump is installed at an altitude of 3500 meters, P_2 will decrease by 88%. And when the ambient temperature is 70 ° C, P_2 will decrease by 78%.

Maximum Operation pressure (bar)

The table below shows the maximum discharge pressures of the various LVS (R) pumps. The suction pressure of the pump + the set pressure must always be lower than the maximum operating pressure of the pump. If the maximum working pressure is exceeded, it can damage the motor bearings and reduce the service life of the mechanical seal.

Model	LVR Max. Operation pressure [bar]		LVS Max. Operation pressure [bar]
	Oval Flange	DIN Flange	
LVR (S) 1	16	25	25
LVR (S) 2	16	25	25
LVR (S) 3	16	25	25
LVR (S) 4	16	25	25
LVR (S) 5	16	25	25
LVR (S) 10		25	25
LVR (S) 15		25	25
LVR (S) 20		25	25
LVR (S) 32-1-1 - 32-7	16		16
LVR (S) 32-8-2 - 32-14	30		30
LVR (S) 45-1-1 - 45-5	16		16
LVR (S) 45-6-2 - 45-11	30		30
LVR (S) 45-12-2 - 45-13-2	33		33
LVR (S) 64-1-1 - 64-5	16		16
LVR (S) 64-6-2 - 64-8-1	30		30
LVR (S) 90-1-1 - 90-4	16		16
LVR (S) 90-5-2 - 90-6	30		30
LVR (S) 120-1 - 120-7	20		20
LVR (S) 150-1-1 - 150-6	20		20
LVR (S) 200-1-D - 200-4	20		20

Minimum Inlet Pressure–Npsh

Calculation of the inlet pressure “H” is recommended in these situations:

- The liquid temperature is high.
- The flow is significantly higher than the rated flow.
- Water is drawn from depths.
- Water is drawn through long pipes.
- Inlet conditions are poor.

To avoid cavitation, make sure that there is a minimum pressure on the suction side of the pump. The maximum suction lift “H” in meters head can be calculated as follows:

H	= $P_b \times 10.2 - NPSH - H_f - H_v - H_s$
P_b	= Barometric pressure in bar. (Barometric pressure can be set to 1 bar). In closed systems, P_b indicates the system pressure in bar.
NPSH	= Net Positive Suction Head in meters head. (To be read from the NPSH curve at the highest flow the pump will be delivering.)
H_f	= Friction loss in suction pipe in meters head. (At the highest flow the pump will be delivering.)
H_v	= Vapor pressure in meters head. (To be read from the vapor pressure scale. “ H_v ” depends on the liquid temperature “ t_m ”)
H_s	= Safety margin = minimum 0.5 meters head.

If the “H” calculated is positive, the pump can operate at a suction lift of maximum “H” meters head.

If the “H” calculated is negative, an inlet pressure of minimum “H” meters head is required.

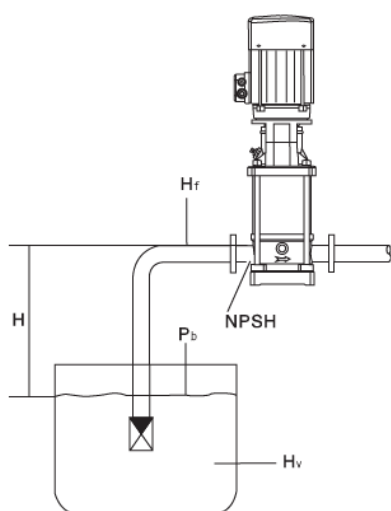

t_m [°C]	H_v [m]
190	126
180	100
170	79
160	62
150	45
140	40
140	35
130	30
130	25
120	20
110	15
100	12
100	10
90	8.0
90	6.0
80	5.0
80	4.0
70	3.0
60	2.0
50	1.5
50	1.0
40	0.8
40	0.6
30	0.4
30	0.3
20	0.2
10	0.1
0	0

Note: To avoid cavitation, never select a pump with a duty point too far to the right on the NPSH curve. Always check the NPSH value of the pump at the highest possible flow.

LVS15 Vertical multicellular stainless steel in line pump



Application

- Transfer of liquids with low viscosity, non-flammable and non-explosive, not containing solid particles or fibers. These liquids must not chemically attack the materials of the pump.
- Water supply for tall buildings, pumping stations, overpressure in drinking water
- Washing stations, heating water circulation, air conditioning water circulation, water treatment systems
- Ultrafiltration, reverse osmosis, distillation systems, municipal swimming pools
- Irrigation: sprinkling, drip
- Food industry
- Fire fighting systems

Pompe

- Liquid temperature: from -20°C to $+120^{\circ}\text{C}$
- Nominal flow: $15\text{ m}^3/\text{h}$
- maximum pressure: 23 bars
- pH between 4 and 10

Moteur

- IE3 motor
- Protection class: IP55
- Maximum ambient temperature: $+40^{\circ}$

Identification codes

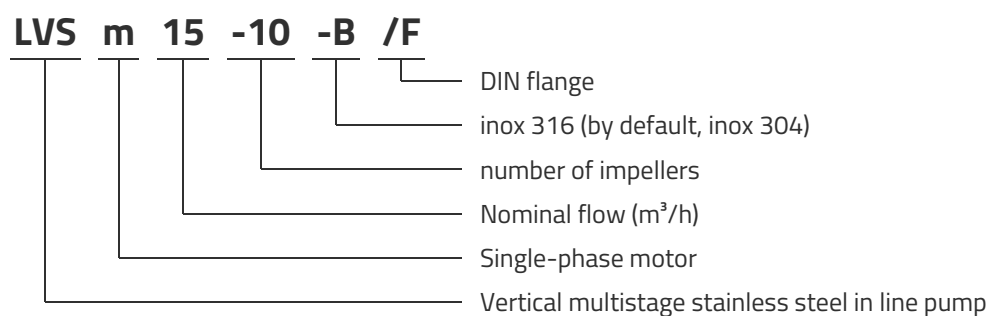

Technical data

MODEL	kW	Q (m ³ /h)	3	6	9	12	15	18	21
		Q (l/min)	50	100	150	200	250	300	350
LVS _m 15-1/F	1.1		15	13	13	12	11	10	9
LVS15-1/F	1.1		15	13	13	12	11	10	9
LVS _m 15-2/F	2.2		28	27	26	25	23	21	18
LVS15-2/F	2.2		28	27	26	25	23	21	18
LVS _m 15-3/F	3		42	41	40	38	35	32	28
LVS15-3/F	3		42	41	40	38	35	32	28
LVS15-4/F	4		58	55	55	51	47	43	38
LVS15-5/F	4		70	68	66	64	58	53	48
LVS15-6/F	5.5		83	82	80	77	71	64	58
LVS15-7/F	5.5		98	96	94	89	83	75	65
LVS15-8/F	7.5		112	110	108	103	96	86	75
LVS15-9/F	7.5		125	123	120	115	108	97	84
LVS15-10/F	11		140	138	136	129	120	109	95
LVS15-12/F	11		168	165	162	155	142	130	114
LVS15-14/F	11		194	192	188	180	166	151	130
LVS15-17/F	15		237	234	230	219	205	185	160

Hydraulic performance

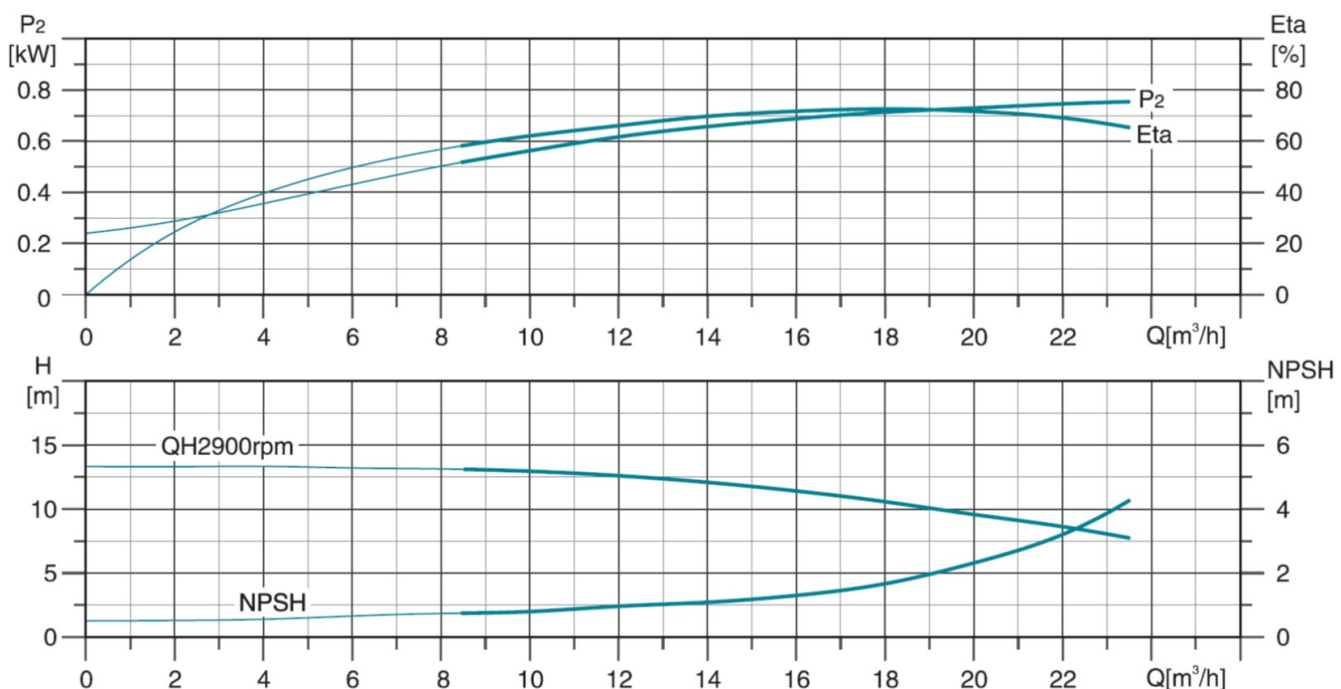
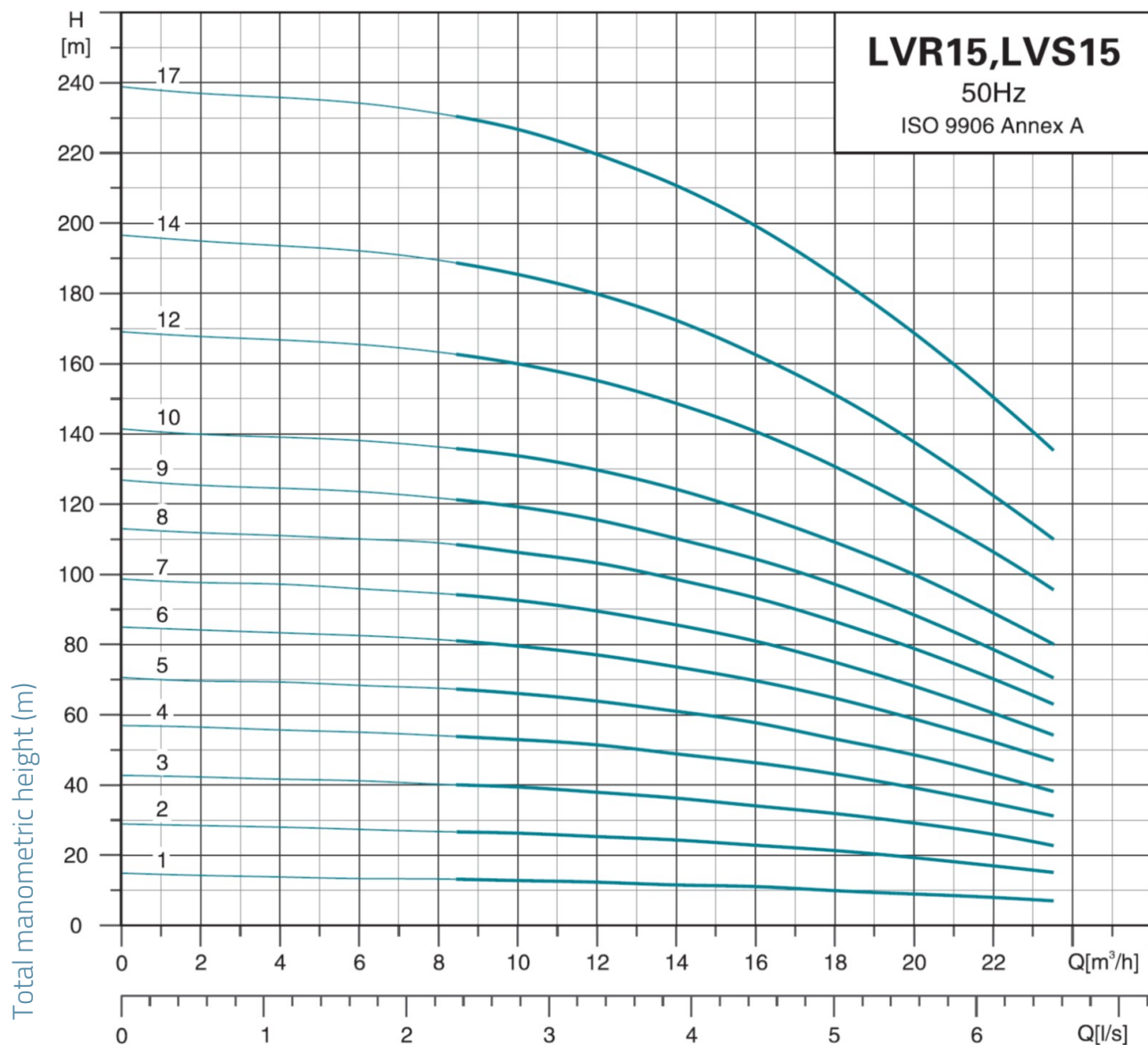

Dimensions

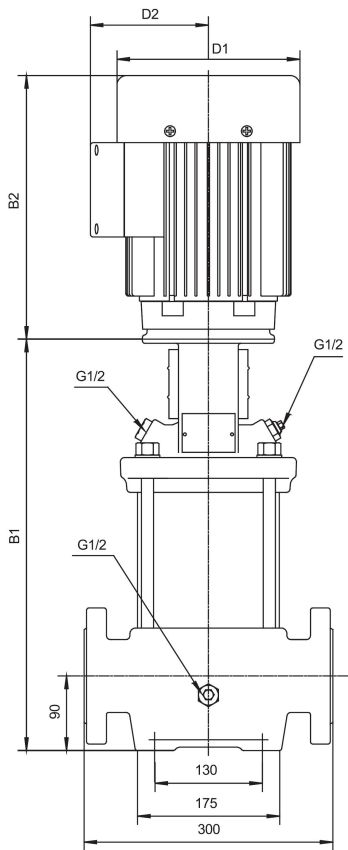

MODEL	B1	B1+B2	D1	D2	poids
LVS _m 15-1/F	354	622	150	125	44.9
LVS15-1/F	354	622	150	125	44.9
LVS _m 15-2/F	415	733	164	127	52.5
LVS15-2/F	415	733	164	127	52.5
LVS _m 15-3/F	465	805	186	120	60.9
LVS15-3/F	465	805	186	120	60.9
LVS15-4/F	510	850	186	120	64.1
LVS15-5/F	555	895	186	120	65.2
LVS15-6/F	632	1029	210	142	75.1
LVS15-7/F	677	1074	210	142	76.1
LVS15-8/F	722	1119	210	142	83.6
LVS15-9/F	767	1164	210	142	83.8
LVS15-10/F	889	1388	254	175	133.2
LVS15-12/F	979	1478	254	175	134.7
LVS15-14/F	1069	1568	254	175	137.2
LVS15-17/F	1204	1703	254	175	155.9

Exploded view

No.	Type	Materials
1	Base	cast iron HT200
2	Drain plug	AISI 304 stainless steel
3	Lower water box	ZG304
4	Diffuser	AISI 304 stainless steel
5	Diffuser with bearing	AISI 304 stainless steel
6	Intermediate diffuser	AISI 304 stainless steel
7	Impeller	AISI 304 stainless steel
8	Final scroll	AISI 304 stainless steel
9	Filling plug	cast iron HT200
10	Lantern	cast iron HT200
11	Coupling	
12	Engine	
13	Coupling protection housing	stainless steel AISI 304 / cast iron HT200
14	Cartridge mechanical seal	
15	Drain plug	AISI 304 stainless steel
16	Pump bottom	ZG304
17	Pump shaft	AISI 304 stainless steel
18	Jacket	AISI 304 stainless steel
19	Flange	ZG35 cast steel

