

Scope of Performance LVS (R)

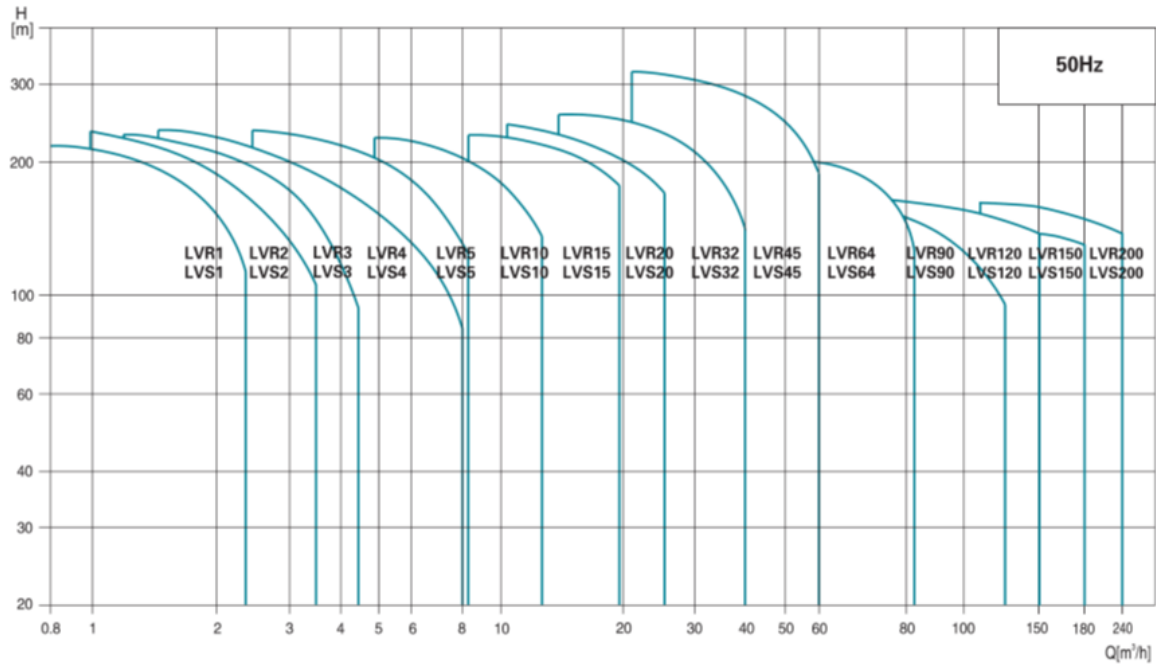

Product Range

MODEL	LVR(S)1	LVR(S)2	LVR(S)3	LVR(S)4	LVR(S)5	LVR(S)10	LVR(S)15	LVR(S)20	LVR(S)32	LVR(S)45	LVR(S)64	LVR(S)90	LVR(S)120	LVR(S)150	LVR(S)200
DESCRIPTION	LVR(S)1	LVR(S)2	LVR(S)3	LVR(S)4	LVR(S)5	LVR(S)10	LVR(S)15	LVR(S)20	LVR(S)32	LVR(S)45	LVR(S)64	LVR(S)90	LVR(S)120	LVR(S)150	LVR(S)200
Rated flow [m³/h]	1	2	3	4	5	10	15	20	32	45	64	90	120	150	200
Flow range [m³/h]	0.7-2.4	1.0-3.5	1.2-4.5	1.5-8	2.5-8.5	5-13	8-23	10.5-29	15-40	22-58	30-85	45-120	60-150	80-180	100-240
Max. pressure [bar]	22	23	24	21	24	22	23	25	28	33	22	20	16	16	16
Motor power [kW]	0.37-2.2	0.37-3	0.37-3	0.37-4	0.37-4	1.1-7.5	1.1-15	1.1-18.5	1.5-30	3-45	4-45	5.5-45	11-75	11-75	18.5-110
Temperature Range [°C]	-20°C--+120°C ( Note: Both the Max. permissible pressure and liquid temperature range refer to the pump capacity.)														
Max. pump efficiency [%]	45	46	55	59	60	65	70	72	78	79	80	81	74	73	79
Pipe connection-LVR															
Oval flange	G1	G1	G1	G1 1/4	G1 1/4	-	-	-	-	-	-	-	-	-	-
DIN flange	DN25	DN25	DN25	DN32	DN32	DN40	DN50	DN50	DN65	DN80	DN100	DN100	DN125	DN125	DN150
Pipe connection-LVS															
Oval flange	-	-	-	-	-	-	-	-	-	-	-	-	-	-	-
DIN flange	DN32	DN32	DN32	DN32	DN32	DN40	DN50	DN50	DN65	DN80	DN100	DN100	DN125	DN125	DN150
Clamp connector	φ42	φ42	φ42	φ42	φ42	-	-	-	-	-	-	-	-	-	-
Threaded connector	R <sub>2</sub> 1 1/4	R <sub>2</sub> 1 1/4	R <sub>2</sub> 1 1/4	R <sub>2</sub> 1 1/4	R <sub>2</sub> 1 1/4	-	-	-	-	-	-	-	-	-	-

## Ambient Temperature

An ambient temperature of over 40 ° C or an installation at an altitude above 1000 meters above sea level requires an oversized motor. Due to low air density and poor cooling, the output power P<sub>2</sub> decreases, as shown in the table below:

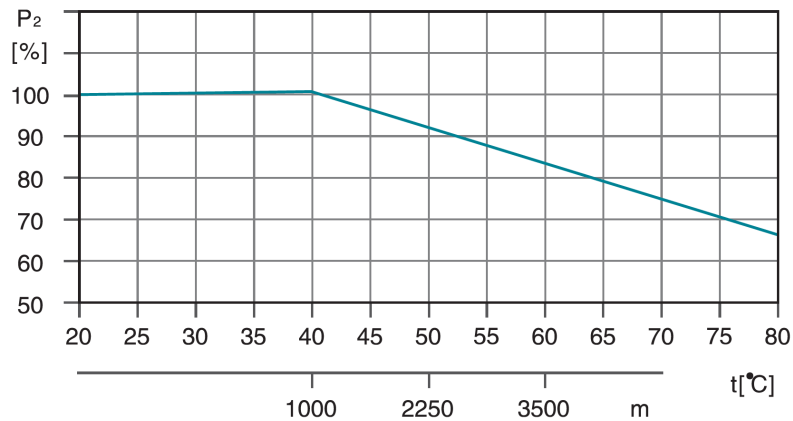

For example, when the pump is installed at an altitude of 3500 meters, P<sub>2</sub> will decrease by 88%. And when the ambient temperature is 70 ° C, P<sub>2</sub> will decrease by 78%.

## Maximum Operation pressure (bar)

The table below shows the maximum discharge pressures of the various LVS (R) pumps. The suction pressure of the pump + the set pressure must always be lower than the maximum operating pressure of the pump. If the maximum working pressure is exceeded, it can damage the motor bearings and reduce the service life of the mechanical seal.

Model	LVR Max. Operation pressure [bar]		LVS Max. Operation pressure [bar]
	Oval Flange	DIN Flange	
LVR (S) 1	16	25	25
LVR (S) 2	16	25	25
LVR (S) 3	16	25	25
LVR (S) 4	16	25	25
LVR (S) 5	16	25	25
LVR (S) 10		25	25
LVR (S) 15		25	25
LVR (S) 20		25	25
LVR (S) 32-1-1 - 32-7	16		16
LVR (S) 32-8-2 - 32-14	30		30
LVR (S) 45-1-1 - 45-5	16		16
LVR (S) 45-6-2 - 45-11	30		30
LVR (S) 45-12-2 - 45-13-2	33		33
LVR (S) 64-1-1 - 64-5	16		16
LVR (S) 64-6-2 - 64-8-1	30		30
LVR (S) 90-1-1 - 90-4	16		16
LVR (S) 90-5-2 - 90-6	30		30
LVR (S) 120-1 - 120-7	20		20
LVR (S) 150-1-1 - 150-6	20		20
LVR (S) 200-1-D - 200-4	20		20

## Minimum Inlet Pressure–Npsh

Calculation of the inlet pressure “H” is recommended in these situations:

- The liquid temperature is high.
- The flow is significantly higher than the rated flow.
- Water is drawn from depths.
- Water is drawn through long pipes.
- Inlet conditions are poor.

To avoid cavitation, make sure that there is a minimum pressure on the suction side of the pump. The maximum suction lift “H” in meters head can be calculated as follows:

$$H = P_b \times 10.2 - NPSH - H_f - H_v - H_s$$

**P<sub>b</sub>** = Barometric pressure in bar. (Barometric pressure can be set to 1 bar). In closed systems, P<sub>b</sub> indicates the system pressure in bar.

**NPSH** = Net Positive Suction Head in meters head. (To be read from the NPSH curve at the highest flow the pump will be delivering.)

**H<sub>f</sub>** = Friction loss in suction pipe in meters head. (At the highest flow the pump will be delivering.)

**H<sub>v</sub>** = Vapor pressure in meters head. (To be read from the vapor pressure scale. “H<sub>v</sub>” depends on the liquid temperature “t<sub>m</sub>”)

**H<sub>s</sub>** = Safety margin=minimum 0.5 meters head.

If the “H” calculated is positive, the pump can operate at a suction lift of maximum “H” meters head.

If the “H” calculated is negative, an inlet pressure of minimum “H” meters head is required.

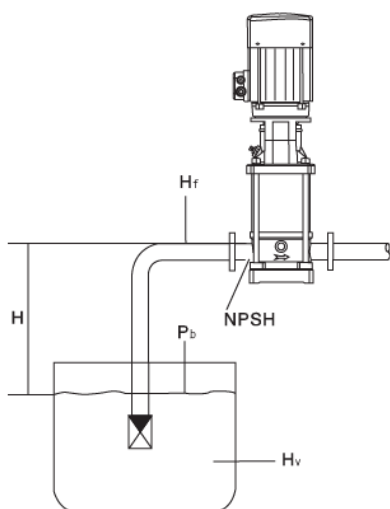

t <sub>m</sub> [°C]	H <sub>v</sub> [m]
190	126
180	100
170	79
160	62
150	45
140	40
140	35
130	30
130	25
120	20
110	15
100	12
100	10
90	8.0
90	6.0
80	5.0
80	4.0
70	3.0
60	2.0
50	1.5
50	1.0
40	0.8
40	0.6
30	0.4
30	0.3
20	0.2
10	0.1
0	0

**Note:** To avoid cavitation, never select a pump with a duty point too far to the right on the NPSH curve. Always check the NPSH value of the pump at the highest possible flow.

## LVS10 Vertical multicellular stainless steel in line pump



### Application

- Transfer of liquids with low viscosity, non-flammable and non-explosive, not containing solid particles or fibers. These liquids must not chemically attack the materials of the pump.
- Water supply for tall buildings, pumping stations, overpressure in drinking water
- Washing stations, heating water circulation, air conditioning water circulation, water treatment systems
- Ultrafiltration, reverse osmosis, distillation systems, municipal swimming pools
- Irrigation: sprinkling, drip
- Food industry
- Fire fighting systems

### Pompe

- Liquid temperature: from  $-20^{\circ}\text{C}$  to  $+120^{\circ}\text{C}$
- Nominal flow:  $10\text{ m}^3/\text{h}$
- maximum pressure: 22 bars
- pH between 4 and 10

### Moteur

- IE3 motor
- Protection class: IP55
- Maximum ambient temperature:  $+40^{\circ}$

### Identification codes

**LVS m 10 -10 -B /F**

- DIN flange
- inox 316 (by default, inox 304)
- number of impellers
- Nominal flow ( $\text{m}^3/\text{h}$ )
- Single-phase motor
- Vertical multistage stainless steel in line pump

### Technical data

MODEL	kW	Q (m <sup>3</sup> /h)	2	4	6	8	10	12
		Q (l/min)	33	67	100	133	167	200
LVS <sub>m</sub> 10-2/F	0.75		20	20	19	18	15	12
LVS <sub>m</sub> 10-3/F	1.1		30	30	29	26	23	18
LVS <sub>m</sub> 10-4/F	1.5		40	40	40	36	32	26
LVS <sub>m</sub> 10-5/F	2.2		51	51	50	46	40	33
LVS <sub>m</sub> 10-6/F	2.2		61	61	59	55	48	39
LVS <sub>m</sub> 10-7/F	3		72	72	70	65	56	46
LVS <sub>m</sub> 10-8/F	3		82	82	80	74	64	53
LVS <sub>m</sub> 10-9/F	3		92	92	89	82	70	59
LVS10-2/F	0.75		20	20	19	18	15	12
LVS10-3/F	1.1		30	30	29	26	23	18
LVS10-4/F	1.5		40	40	40	36	32	26
LVS10-5/F	2.2		51	51	50	46	40	33
LVS10-6/F	2.2		61	61	59	55	48	39
LVS10-7/F	3		72	72	70	65	56	46
LVS10-8/F	3		82	82	80	74	64	53
LVS10-9/F	3		92	92	89	82	70	59
LVS10-10/F	4		102	102	100	93	80	66
LVS10-12/F	4		122	122	119	110	95	79
LVS10-14/F	5.5		144	144	140	130	113	94
LVS10-16/F	5.5		163	163	159	148	128	106
LVS10-18/F	7.5		186	186	182	169	147	123
LVS10-20/F	7.5		206	204	201	188	164	136
LVS10-22/F	7.5		226	226	221	206	178	147

# Hydraulic performance

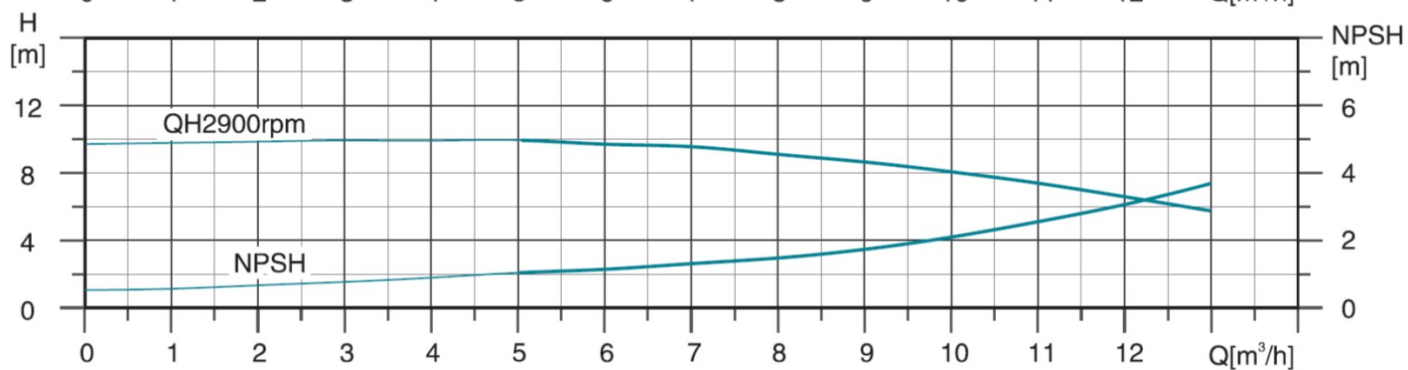
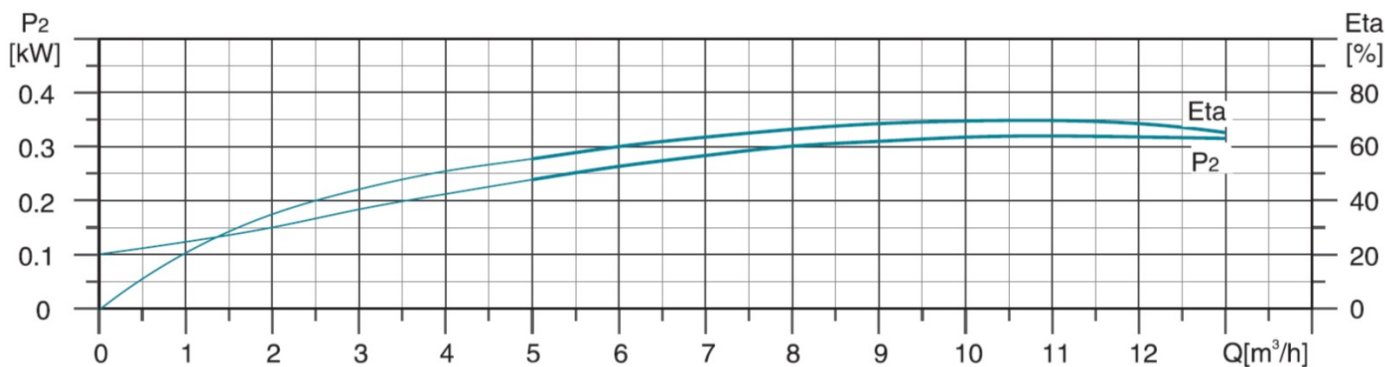
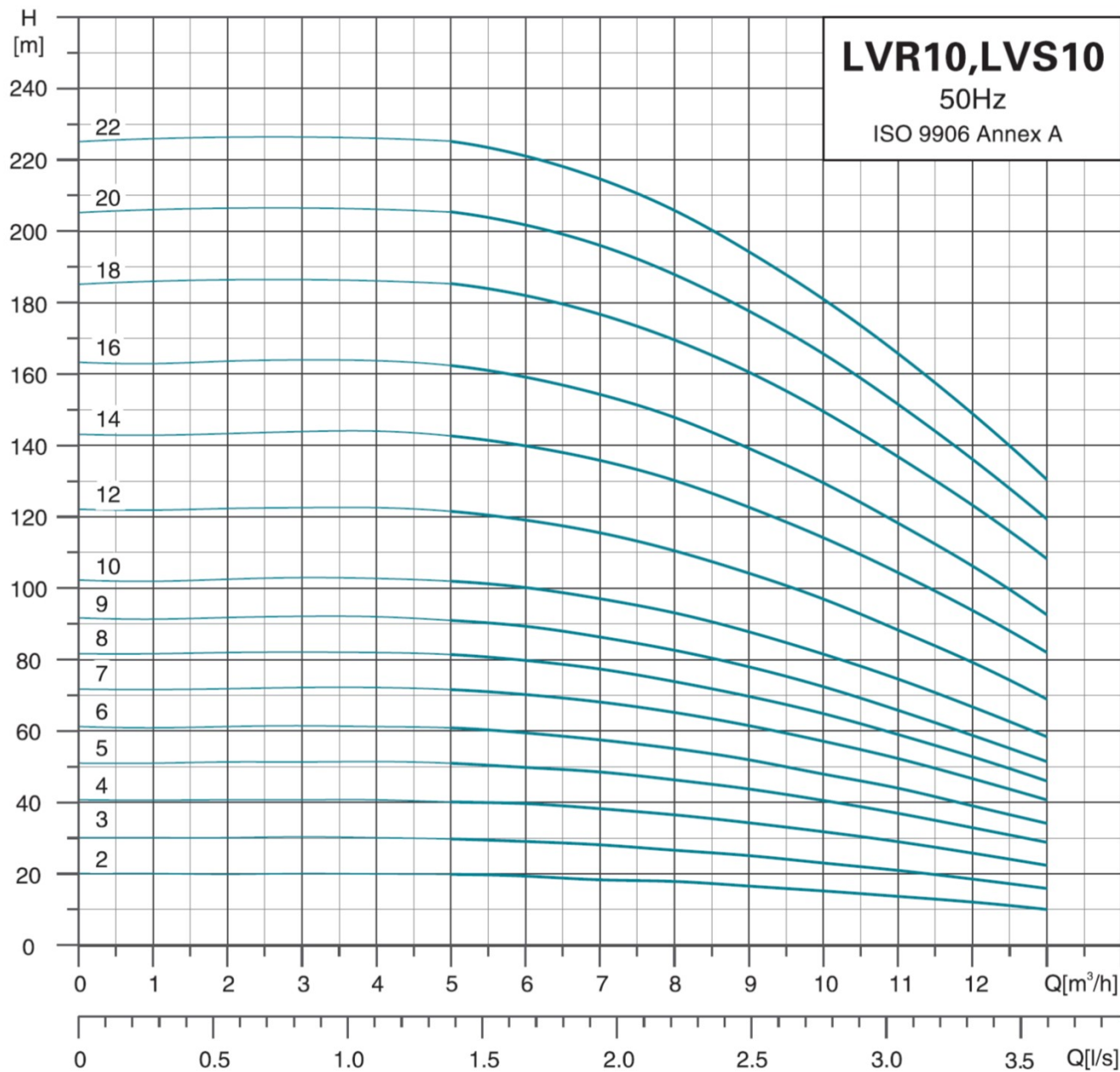

# Dimensions

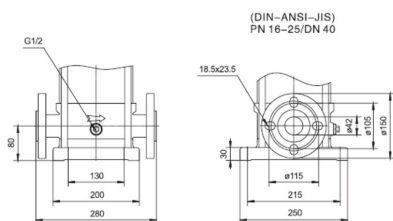
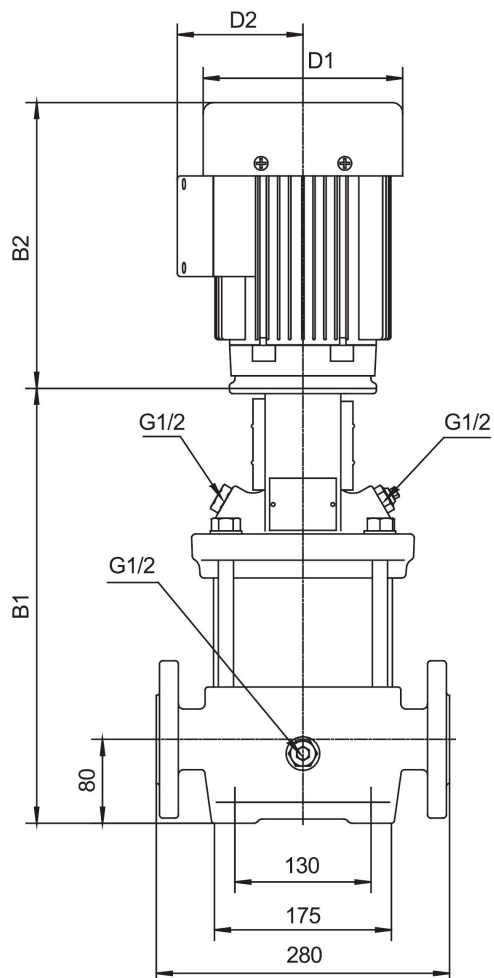

LVS

## Brides LVS10

MODEL	B1	B1+B2	D1	D2	poids
LVS <sub>m</sub> 10-2/F	351	619	150	125	40.6
LVS <sub>m</sub> 10-3/F	381	649	150	125	41.1
LVS <sub>m</sub> 10-4/F	427	745	164	127	48.5
LVS <sub>m</sub> 10-5/F	457	775	164	127	51.9
LVS <sub>m</sub> 10-6/F	487	805	164	127	52.5
LVS <sub>m</sub> 10-7/F	522	862	186	120	60.6
LVS <sub>m</sub> 10-8/F	552	892	186	120	62.1
LVS <sub>m</sub> 10-9/F	582	922	186	120	63.2
LVS10-2/F	351	619	150	125	40.6
LVS10-3/F	381	649	150	125	41.1
LVS10-4/F	427	745	164	127	48.5
LVS10-5/F	457	775	164	127	51.9
LVS10-6/F	487	805	164	127	52.5
LVS10-7/F	522	862	186	120	60.6
LVS10-8/F	552	892	186	120	62.1
LVS10-9/F	582	922	186	120	63.2
LVS10-10/F	612	952	186	120	66.5
LVS10-12/F	672	1012	186	120	73.1
LVS10-14/F	764	1161	210	142	77.1
LVS10-16/F	824	1221	210	142	80.3
LVS10-18/F	884	1281	210	142	86.9
LVS10-20/F	944	1341	210	142	86.9
LVS10-22/F	1004	1401	210	142	95.6

No.	Type	Materials
1	Base	cast iron HT200
2	Drain plug	AISI 304 stainless steel
3	Lower water box	ZG304
4	Diffuser	AISI 304 stainless steel
5	Diffuser with bearing	AISI 304 stainless steel
6	Intermediate diffuser	AISI 304 stainless steel
7	Impeller	AISI 304 stainless steel
8	Final scroll	AISI 304 stainless steel
9	Filling plug	cast iron HT200
10	Lantern	cast iron HT200
11	Coupling	
12	Engine	
13	Coupling protection housing	AISI 304 stainless steel
14	Cartridge mechanical seal	
15	Drain plug	AISI 304 stainless steel
16	Pump bottom	ZG304
17	Pump shaft	AISI 304 stainless steel
18	Jacket	AISI 304 stainless steel
19	Flange	ZG35 cast steel

