

ECH10 Horizontal multistage stainless steel pump

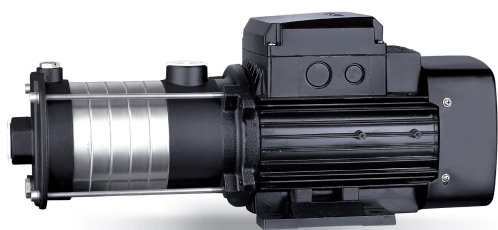

ECH

Application

- Water supply for tall buildings, pumping stations, overpressure
- Washing stations, heating water circulation, air conditioning water circulation, water treatment systems
- Ultrafiltration, reverse osmosis, distillation systems, municipal swimming pools
- Irrigation: sprinkling, drip
- Industry
- Fire fighting systems

Pompe

- Stainless steel shaft
- Max liquid temperature: +85°C
- Max suction height: 8 m
- Maximum operating pressure: 4.7 bars
- pH between 4 and 10

Moteur

- IE3 motor
- Protection class: IP55
- Insulation class: F
- Maximum ambient temperature: +40°
- Integrated thermal protection for single-phase versions
- Altitude: up to 1000 m

Identification codes

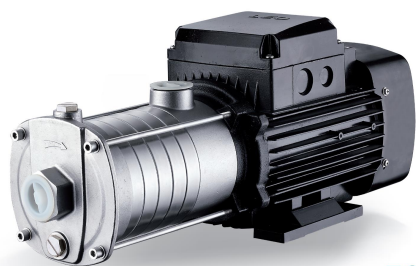
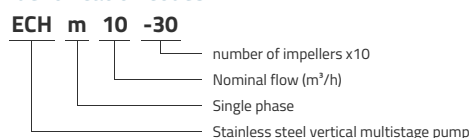

ECHS

Technical data

MODEL	kW	Q (m³/h)	6	7	8	9	10	11	12
		Q (l/min)	100	117	133	150	167	183	200
ECHm10-10	0.75	9.1	8.7	8.2	7.7	6.8	5.8		
ECH10-10	0.75	9.1	8.7	8.2	7.7	6.8	5.8		
ECHm10-20	0.75	17.9	17.1	16.3	15.3	14	12.5	10.6	
ECH10-20	0.75	17.9	17.1	16.3	15.3	14	12.5	10.6	
ECHm10-30	1.1	27.1	26.3	24.9	23.4	21.4	19.3	16.9	
ECH10-30	1.1	27.1	26.3	24.9	23.4	21.4	19.3	16.9	
ECHm10-40	1.5	38.6	37.6	35.9	33.9	31.2	28.2	24.6	
ECH10-40	1.5	38.6	37.6	35.9	33.9	31.2	28.2	24.6	
ECHm10-50	2.2	47.8	46.4	44.4	42.2	39.5	35.9	31.1	
ECH10-50	2.2	47.8	46.4	44.4	42.2	39.5	35.9	31.1	

Dimensions

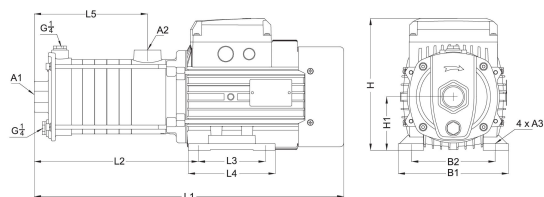

MODEL	L1	L2	L3	L4	L5	B1	B2	H	H1	A1	A2	A3
ECHm10-10	430	212	100	130	121	165	125	204.5	80	1½	1¼	10
ECH10-10	430	212	100	130	121	165	125	204.5	80	1½	1¼	10
ECHm10-20	430	212	100	130	121	165	125	204.5	80	1½	1¼	10
ECH10-20	430	212	100	130	121	165	125	204.5	80	1½	1¼	10
ECHm10-30	460.5	242.5	100	130	151.5	165	125	504.5	80	1½	1¼	10
ECH10-30	460.5	242.5	100	130	151.5	165	125	504.5	80	1½	1¼	10
ECHm10-40	549.5	261.5	125	150	182	180	140	217.5	90	1½	1¼	10
ECH10-40	549.5	261.5	125	150	182	180	140	217.5	90	1½	1¼	10
ECHm10-50	579.5	291.5	125	150	212	180	140	217.5	90	1½	1¼	10
ECH10-50	579.5	291.5	125	150	212	180	140	217.5	90	1½	1¼	10

Hydraulic performance

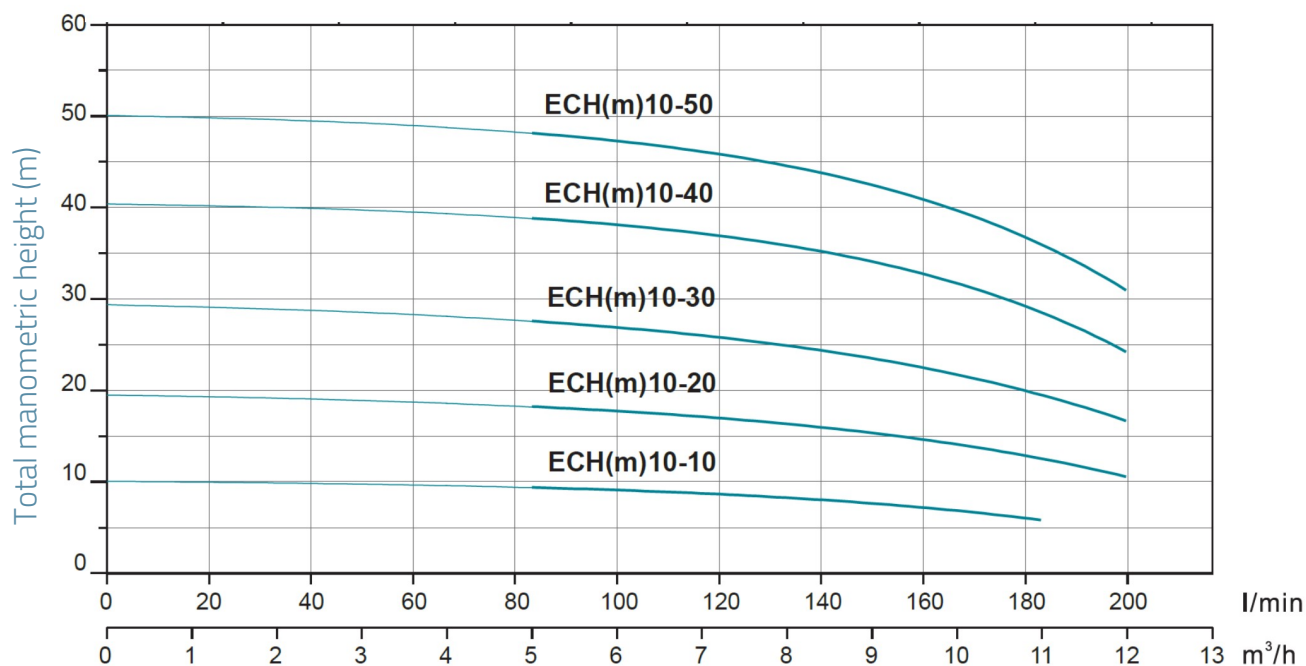

Exploded view

No.	Type	Materials
1	Fan cover	O8F steel
2	Fan	polypropylene
3	Rear cover	cast aluminum ZL102
4	Rotor	
5	Bearing	
6	Electric box cover	cast aluminum ZL102
7	Stator	
8	Lantern	cast iron HT200
9	Outlet diffuser	cast iron HT200
10	Mechanical seal	silicon carbide / graphite
11	Shim	AISI 304 stainless steel
12	Diffuser	AISI 304 stainless steel
13	Bearing	AISI 304 stainless steel
14	Impeller	AISI 304 stainless steel
15	Front cover	cast iron HT200
16	Seal	PolyTetraFluoroEthylene

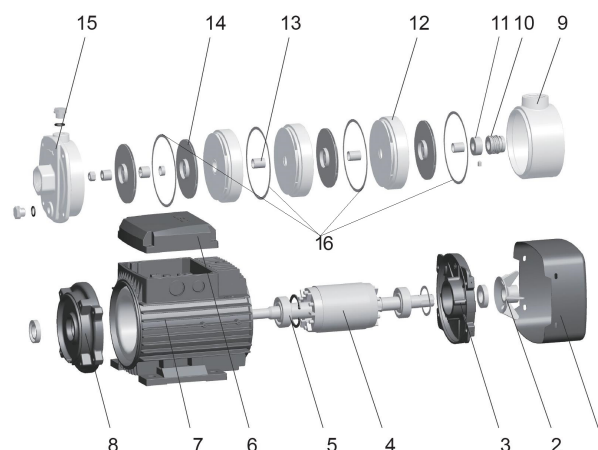

Packaging

MODEL	Weight (kg)	Length L (mm)	Width W (mm)	Height H (mm)
ECHm10-10	20.7	503	235	268
ECH10-10	20.7	503	235	268
ECHm10-20	20.8	503	235	268
ECH10-20	20.8	503	235	268
ECHm10-30	21.9	503	235	268
ECH10-30	21.9	503	235	268
ECHm10-40	28.2	618	245	283
ECH10-40	28.2	618	245	283
ECHm10-50	30.6	618	245	283
ECH10-50	30.6	618	245	283

