

3(4)ACm Centrifugal multistage cast iron pump



Application

- Transfer of clear water or other liquids chemically and physically comparable to water
- Suitable for industrial use and water supply, overpressure and fire system, garden irrigation, long distance water transfer, air conditioning system, circulation and overpressure for hot and cold water, etc ...

Pompe

- Special anti-rust treatment (cataphoresis) for the cast iron pump body and the support
- AISI 304 stainless steel shaft
- Maximum liquid temperature: +40°C
- Maximum suction height: 8 m
- Self-priming

Moteur

- Integrated thermal protection for single-phase motors
- Insulation class: F
- Protection class: IPX4
- Maximum ambient temperature: +40°C

Identification codes

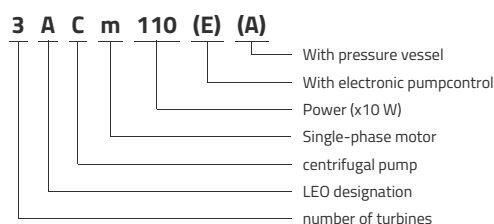

Technical data

MODEL	kW	Q (l/min)	Q (m³/h)																
			0	0.3	0.6	0.9	1.2	1.5	1.8	2.4	3	3.6	4.2	4.8	5.4				
3ACm45	0.45		35	33.5	32.5	31.5	30	28.5	26.5	23	18.5	14	9						
3ACm60	0.6		36	35.5	35	34.5	34	33.5	32.5	30.5	28.5	26	23	19	13.5				
4ACm60	0.6		46.5	45	44	42.5	40.5	38.5	36	30	24	17	10						
4ACm75	0.75		46.5	45	44	43	42	41	40	38	35.5	32.5	28	23	17				
4ACm75E (With pumpcontrol)	0.75		46.5	45	44	43	42	41	40	38	35.5	32.5	28	23	17				
4ACm75A3 (With pressure vessel)	0.75		46.5	45	44	43	42	41	40	38	35.5	32.5	28	23	17				
4AC75	0.75		46.5	45	44	43	42	41	40	38	35.5	32.5	28	23	17				

Dimensions

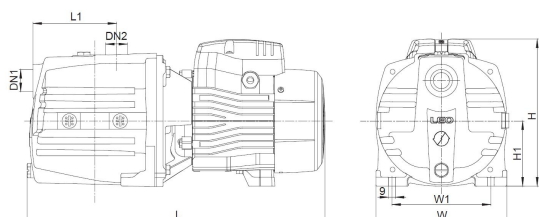

MODEL	DN1	DN2	L	W	H	L1	W1	H1
3ACm45	1	1	368	180	183	90	136	90
3ACm60	1	1	485	180	202	90	136	90
4ACm60	1	1	405	180	183	115	136	90
4ACm75	1	1	510	180	202	115	136	90
4ACm75E (With pumpcontrol)	1	1	510	180	202	115	136	90
4ACm75A3 (With pressure vessel)	1	1	510	180	202	115	136	90
4AC75	1	1	510	180	202	115	136	90

Hydraulic performance

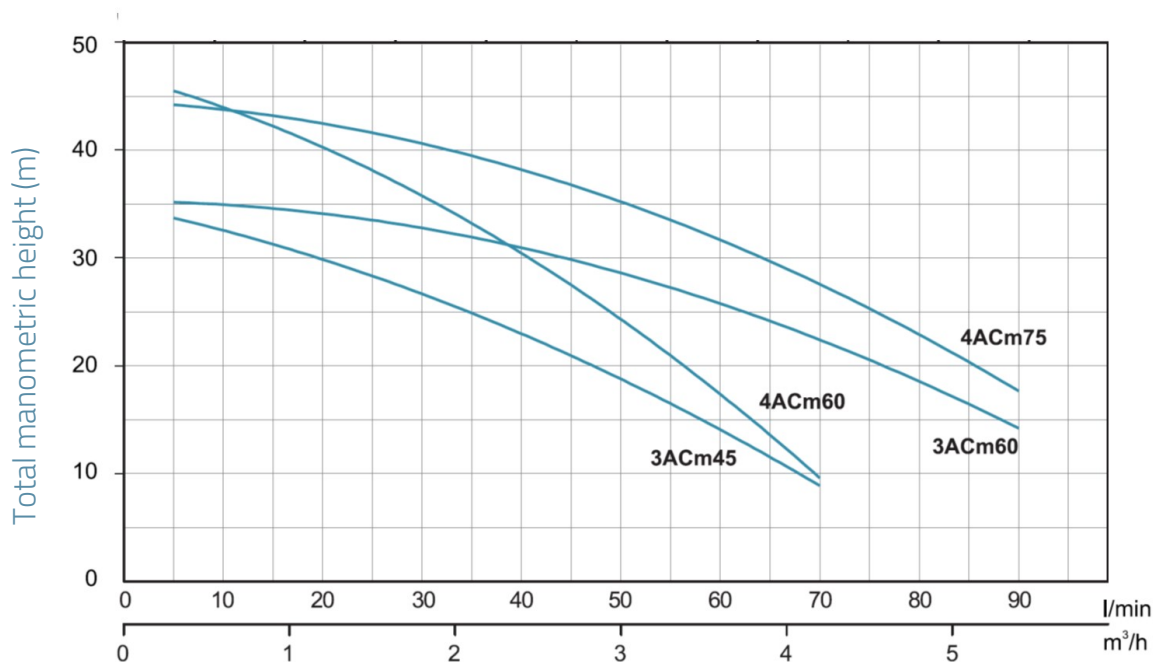

Exploded view

No.	Type	Materials
1	Pump body	cast iron HT200
2	Diffuser	noryl (PPO)
3	Non-return valve	noryl (PPO)
4	Diffuser	noryl (PPO)
5	Impeller	noryl (PPO)
6	Intermediate diffuser	noryl (PPO)
7	Intermediate diffuser	noryl (PPO)
8	Positioning guide	noryl (PPO)
9	Mechanical seal	carbon / ceramic
10	Pump bottom	cast iron HT200
11	Oil seal	
12	Lantern	cast aluminum ZL102
13	Bearing	
14	Rotor	
15	Stator	
16	Electric box cover	PA6 resin
17	Capacitor	
18	Rear cover	cast aluminum ZL102
19	Fan	polypropylene
20	Fan cover	polypropylene
21	O-ring	nitrile rubber (NBR)

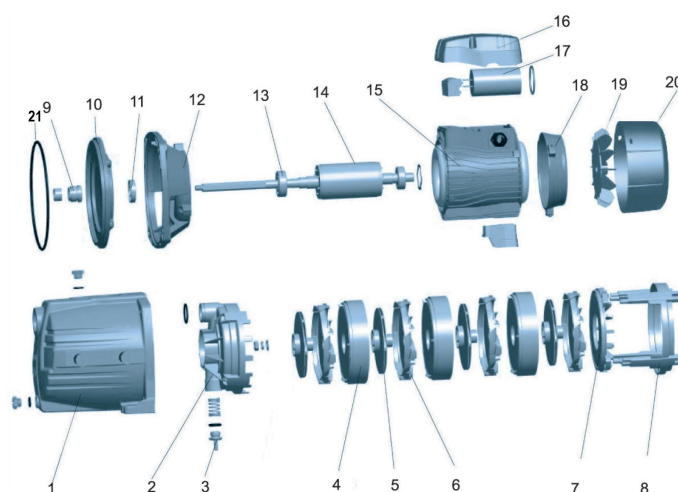

Packaging

MODEL	Weight (kg)	Length L (mm)	Width W (mm)	Height H (mm)
3ACm45	13.2	410	200	210
3ACm60	15.3	435	200	230
4ACm60	16	460	200	230
4ACm75	17	460	200	230
4ACm75E (With pumpcontrol)	0	0	0	0
4ACm75A3 (With pressure ves)	0	0	0	0
4AC75	17	460	200	230

