

3(4)ACm Bomba centrífuga multicelular de hierro fundido.



Application

- Transferencia de agua limpia u otros líquidos química y físicamente comparables al agua
- Adecuado para uso industrial y suministro de agua, sobrepresión y sistema contra incendios, riego de jardines, transferencia de agua a larga distancia, sistema de aire acondicionado, circulación y sobrepresión para agua fría y caliente, etc.

Pompe

- Tratamiento anticorrosión especial (cataforesis) para el cuerpo de la bomba de hierro fundido y el eje de acero inoxidable AISI 304 de soporte
- Temperatura máxima del líquido: + 40 ° C
- Altura máxima de succión: 8 m
- Autocebado

Moteur

- Protección térmica integrada para motores monofásicos
- Clase de aislamiento: F
- Clase de protección: IPX4
- Temperatura ambiente máxima: + 40 ° C

Códigos de identificación

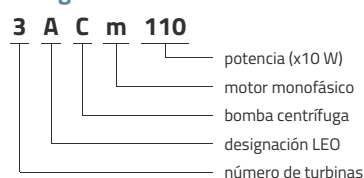

Datos técnicos

MODEL	kW	Q (m³/h)	Q (l/min)														
			0	0.3	0.6	0.9	1.2	1.5	1.8	2.4	3	3.6	4.2	4.8	5.4		
3ACm45	0.45	35	33.5	32.5	31.5	30	28.5	26.5	23	18.5	14	9					
3ACm60	0.6	36	35.5	35	34.5	34	33.5	32.5	30.5	28.5	26	23	19	13.5			
4ACm60	0.6	46.5	45	44	42.5	40.5	38.5	36	30	24	17	10					
4ACm75	0.75	46.5	45	44	43	42	41	40	38	35.5	32.5	28	23	17			
4ACm75E (With pumpcontrol)	0.75	46.5	45	44	43	42	41	40	38	35.5	32.5	28	23	17			
4ACm75A3 (With pressure vessel)	0.75	46.5	45	44	43	42	41	40	38	35.5	32.5	28	23	17			
4AC75	0.75	46.5	45	44	43	42	41	40	38	35.5	32.5	28	23	17			

Dimensiones

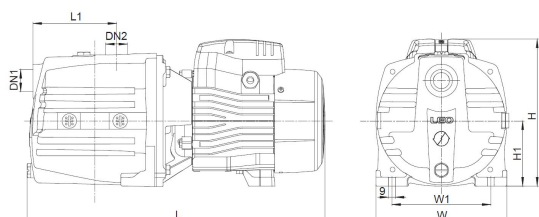

MODEL	DN1	DN2	L	W	H	L1	W1	H1
3ACm45	1	1	368	180	183	90	136	90
3ACm60	1	1	485	180	202	90	136	90
4ACm60	1	1	405	180	183	115	136	90
4ACm75	1	1	510	180	202	115	136	90
4ACm75E (With pumpcontrol)	1	1	510	180	202	115	136	90
4ACm75A3 (With pressure vessel)	1	1	510	180	202	115	136	90
4AC75	1	1	510	180	202	115	136	90

Rendimiento hidráulico

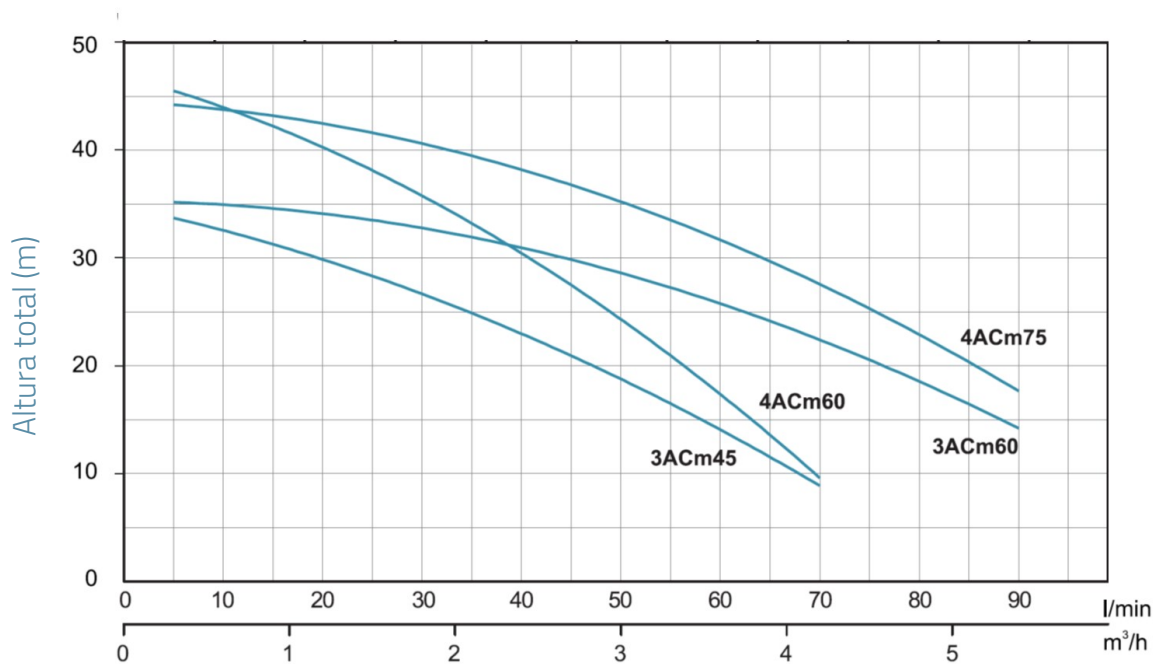

Vista en despiece ordenado

No.	Type	Materiales
1	cuerpo de la bomba	hierro fundido HT200
2	serpentina	noryl (PPO)
3	válvula de retención	noryl (PPO)
4	serpentina	noryl (PPO)
5	turbina	noryl (PPO)
6	difusor intermedio	noryl (PPO)
7	difusor intermedio	noryl (PPO)
8	guía de posicionamiento	noryl (PPO)
9	sello mecánico	carbón / cerámica
10	parte inferior de la bomba	hierro fundido HT200
11	sello de aceite	
12	linterna	fundición de aluminio ZL102
13	laminación	
14	rotor	
15	estator	
16	tapa de la caja de terminales	Resina PA6
17	condensador	
18	soporte del cojinete trasero del motor	fundición de aluminio ZL102
19	ventilador	polipropileno
20	versión de fan	polipropileno
21	sello del cuerpo	caucho de nitrilo (NBR)

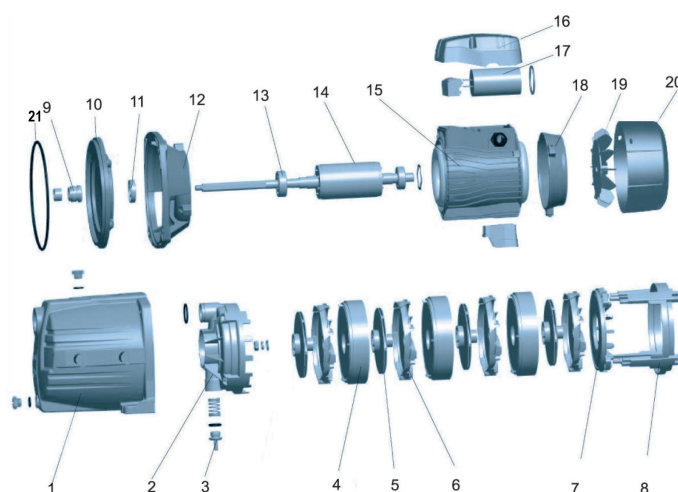

Packaging

MODEL	Peso (kg)	Longitud L (mm)	Anchura W (mm)	Altura H (mm)
3ACm45	13.2	410	200	210
3ACm60	15.3	435	200	230
4ACm60	16	460	200	230
4ACm75	17	460	200	230
4ACm75E (With pumpcontrol)	0	0	0	0
4ACm75A3 (With pressure ves)	0	0	0	0
4AC75	17	460	200	230

