

XZS80-50 Centrifugal monobloc pump with rigid coupling

Application

- The XZS standardized monobloc centrifugal pump is a new generation of centrifugal pump dedicated to conveying water and various industrial fluids. This pump is suitable for various temperatures, flow rates and pressures. It is manufactured using advanced technologies.
- Drinking water supply, filtration and overpressure of water.
- Industrial pressurization, flow dampening system, cleaning system
- Transport of industrial liquids, hot water supply, condensing system, cooling system, air conditioning system.
- Water treatment, water distillation system, separator, swimming pool
- Irrigation
- Petrochemical and medical industries, etc ...

Pompe

- Conditions of use: Clear, non-flammable and non-explosive liquid, without particles or fibers
- Liquid temperature: from -15°C to +90°C
- Nominal flow entre 0.7 and 132 m³/h
- HMT between 9 and 58 m
- pH between 3 and 9
- Carbon / SiC / NBR mechanical seal

Moteur

- Protection class: IP55
- Maximum ambient temperature: +40°
- Maximum working pressure: 10 bars

Identification codes

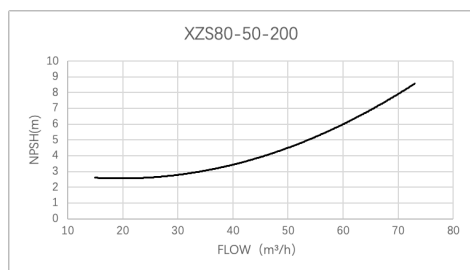
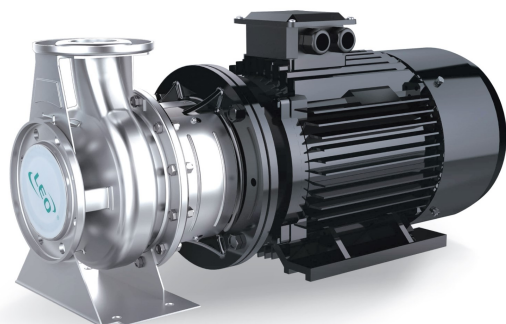
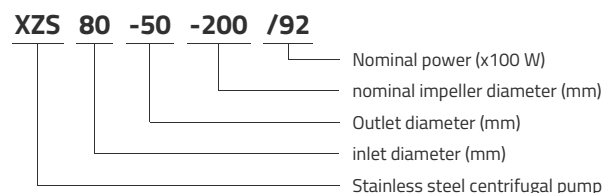

Technical data

MODEL	kW	Q (m ³ /h)								
		0	30	36	42	48	60	72		
		Q (l/min)								
		0	500	600	700	800	1000	1200		
XZS80-50-200/92	9.2	53	48	47.5	46.5	44.5	39.5	34		
XZS80-50-200/110	11	57.5	53	51	50.5	50	47	41		

Dimensions

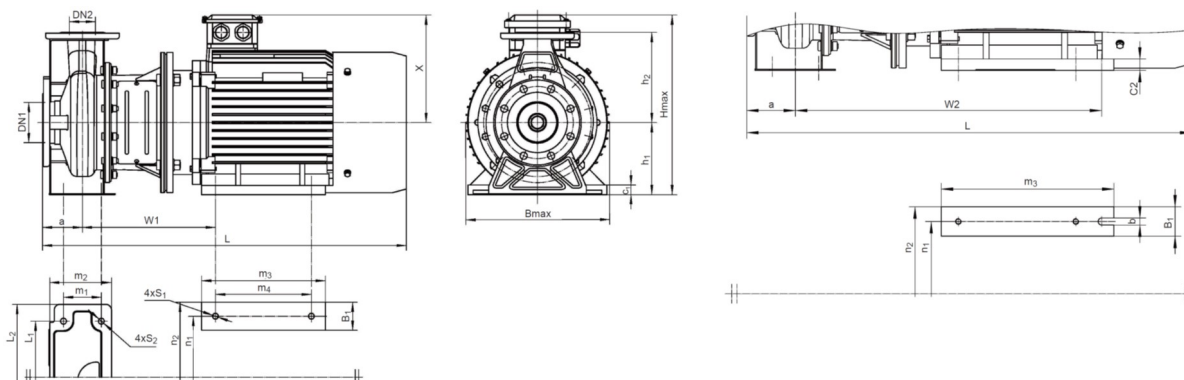

MODEL	DN1	DN2	a	w1	w2	L1	L2	m1	m2	m3	m4	n1	n2	h1	h2	S1	S2	B1	b	c1	c2	X	Bmax	Hmax	L
XZS80-50-200/92	80	50	100	314		212	265	70	146	210	260	254	320	160	200	14.5	14	65		20		260	350	420	816
XZS80-50-200/110	80	50	100	314		212	265	70	146	210	260	254	320	160	200	14.5	14	65		20		260	350	420	816

Hydraulic performance

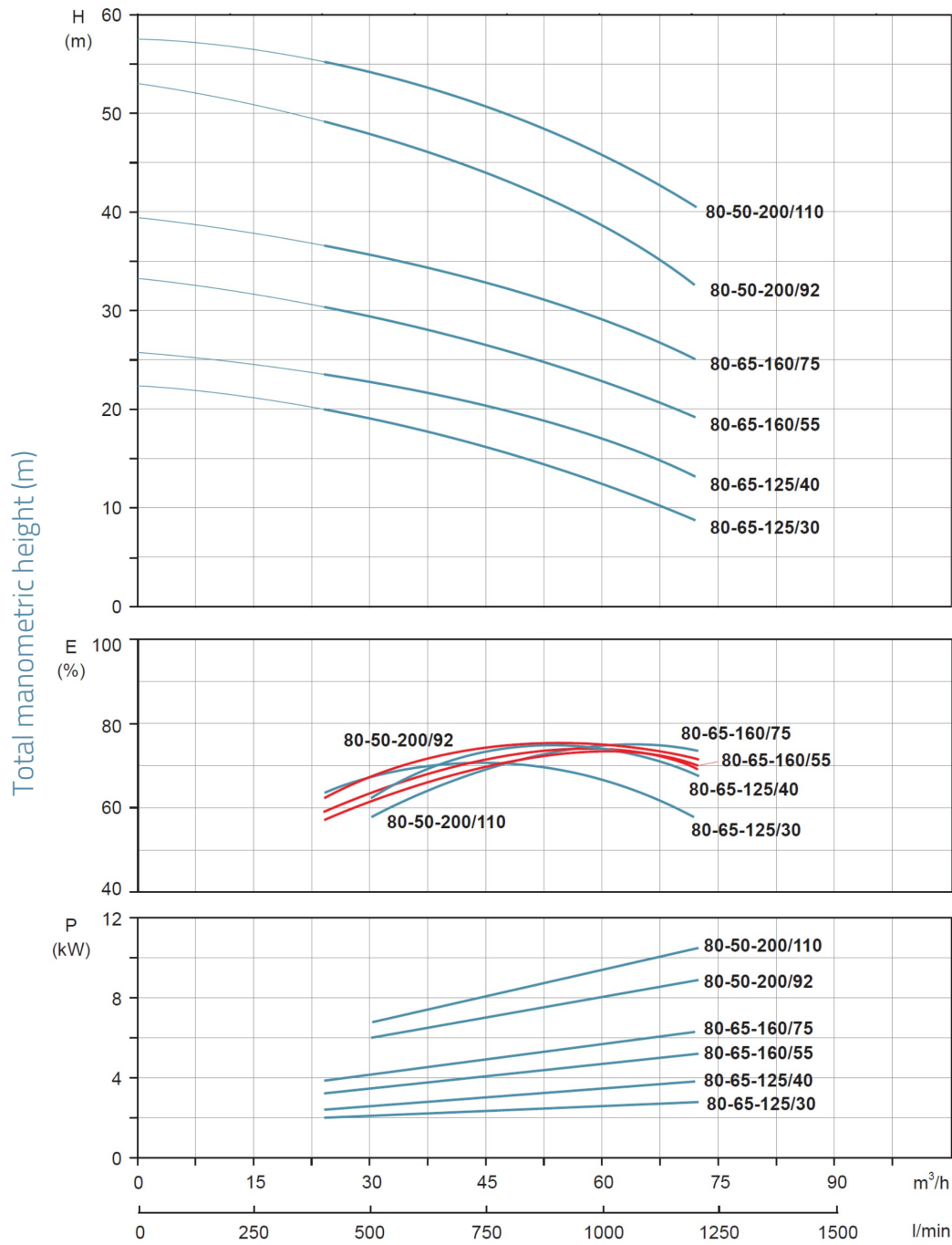

Exploded view

No.	Type	Materials
1	Pump body	austenitic stainless steel
2	Impeller	austenitic stainless steel
3	O-ring	nitrile rubber (NBR)
4	Rear cover	austenitic stainless steel
5	Lantern	cast iron HT200
6	Engine	
7	Rigid coupling	austenitic stainless steel
8	Nameplate	austenitic stainless steel
9	Coupling protection housing	austenitic stainless steel
10	Mechanical seal	silicon carbide / graphite

