

XZS100-80-125 Stainless steel centrifugal pump monobloc

Application

- The XZS standardized monobloc centrifugal pump is a new generation of centrifugal pump dedicated to conveying water and various industrial fluids. This pump is suitable for various temperatures, flow rates and pressures. It is manufactured using advanced technologies.
- Drinking water supply, filtration and overpressure of water.
- Industrial pressurization, flow dampening system, cleaning system
- Transport of industrial liquids, hot water supply, condensing system, cooling system, air conditioning system.
- Water treatment, water distillation system, separator, swimming pool
- Irrigation
- Petrochemical and medical industries, etc ...

Pompe

- Conditions of use: Clear, non-flammable and non-explosive liquid, without particles or fibers
- Liquid temperature: from -15°C to +90°C
- Nominal flow entre 0.7 and 132 m³/h
- HMT between 9 and 58 m
- pH between 3 and 9
- Carbon / SiC / NBR mechanical seal

Moteur

- Protection class: IP55
- Maximum ambient temperature: +40°
- Maximum working pressure: 10 bars

Identification codes

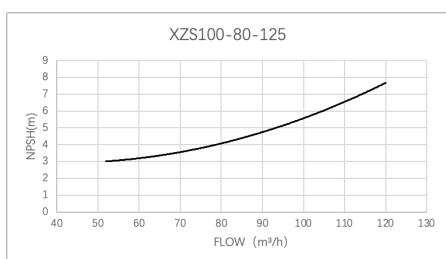
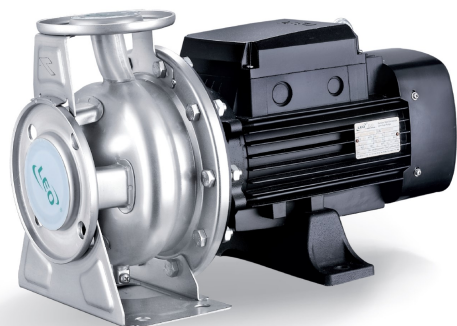
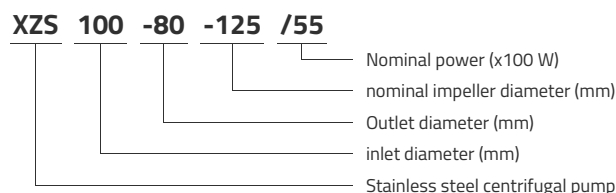

Technical data

MODEL	kW	Q (m³/h)									
		0	36	42	48	60	72	90	108	114	
		Q (l/min)									
		0	600	700	800	1000	1200	1500	1800	1900	
XZS100-80-125/40	4	20	17.5	16.5	15.5	14	12	7			
XZS100-80-125/55	5.5	23	21.5	20.5	20	18	16	12	7.5		
XZS100-80-125/75	7.5	29	27.5	26.5	25.5	23.5	21.5	17.5	13	12	

Dimensions

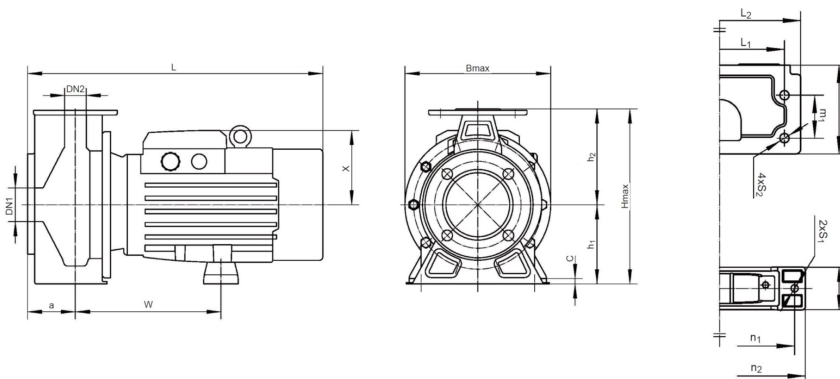

MODEL	DN1	DN2	a	w	L1	L2	m1	m2	n1	n2	h1	h2	S1	S2	B	C	X	Bmax	Hmax	L
XZS100-80-125/40	100	80	100	256	212	280	95	155	225	260	160	180	12	15	75	15	124	280	340	524
XZS100-80-125/55	100	80	100	258	212	280	95	155	245	280	160	180	12	15	70	15	142	280	340	575
XZS100-80-125/75	100	80	100	258	212	280	95	155	245	280	160	180	12	15	70	15	142	280	340	575

Hydraulic performance

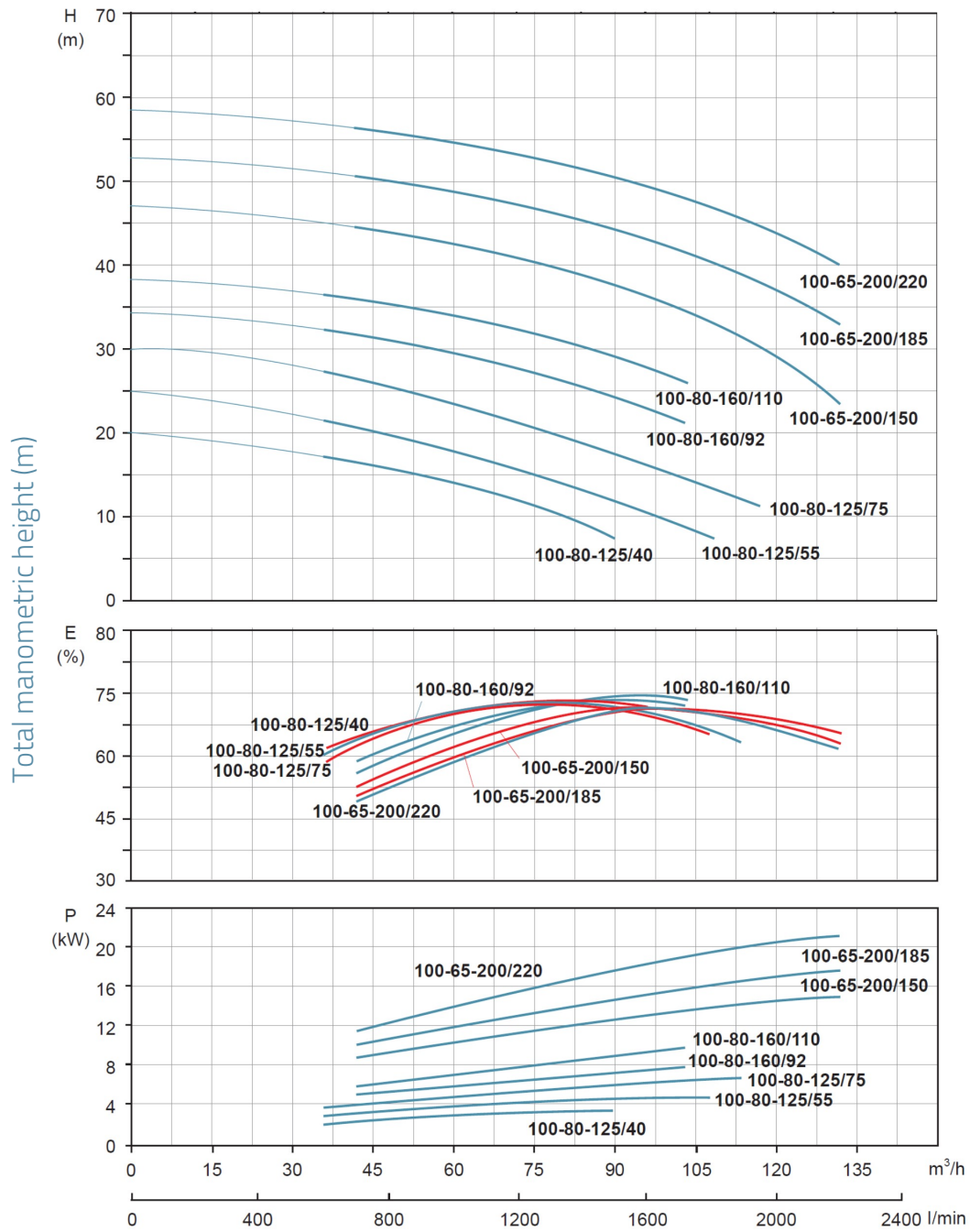

Exploded view

No.	Type	Materials
1	Pump body	austenitic stainless steel
2	Impeller	austenitic stainless steel
3	O-ring	nitrile rubber (NBR)
4	Lantern	cast iron HT200
5	Oil seal	
6	Bearing	
7	Rotor	
8	Base	cast iron HT200
9	Bearing	
10	Oil seal	
11	Fan	polypropylene
12	Fan cover	Ø8F steel
13	Rear cover	cast aluminum ZL102
14	Nameplate	austenitic stainless steel
15	Stator	
16	Electric box cover	cast aluminum ZL102
17	Terminal board	
18	Cable gland	
19	Pump bottom	austenitic stainless steel
20	Mechanical seal	silicon carbide / graphite

