

LKS-S Well pump



Application

- Pumping for wells, tanks
- For domestic applications (watering, small irrigation, rainwater recovery)

Pompe

- High HMT thanks to several stages of impellers
- Stainless steel jacket
- Maximum liquid temperature: +35°C
- Maximum immersion depth: 5 m
- Maximum particle diameter: 1 mm

Moteur

- Rewindable motor
- Integrated thermal protection
- Insulation class: F
- Protection class: IPX8

Identification codes

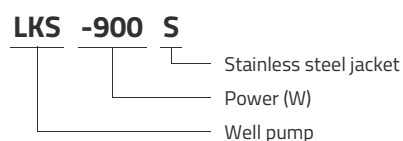

Technical data

MODEL	kW	Q (m³/h)													
		0.5	1	1.5	2	2.5	3	3.5	4	4.5	5	5.5	6	6.5	
	Q (l/min)	8	17	25	33	42	50	58	67	75	83	92	100	108	
LKS-900S	0.9	31.5	31	30	28.5	27.5	26	23.5	22	19	17.5	14.5	11	7.5	
LKS-1100S	1.1	42	40	38	37.5	35	32.5	30	27	23	20	16.5	12.5	8.5	
LKS-1300S	1.3	51	50	47.5	45	42.5	40	36.5	32.5	29	25	21	16.5	11	

Hydraulic performance

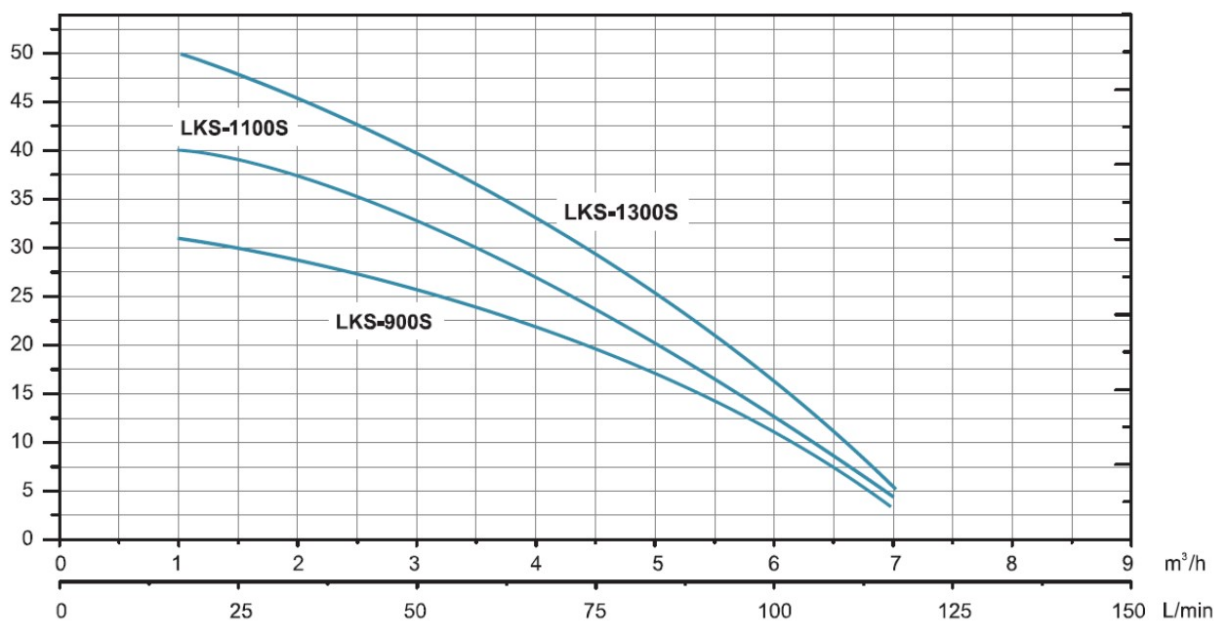

Dimensions

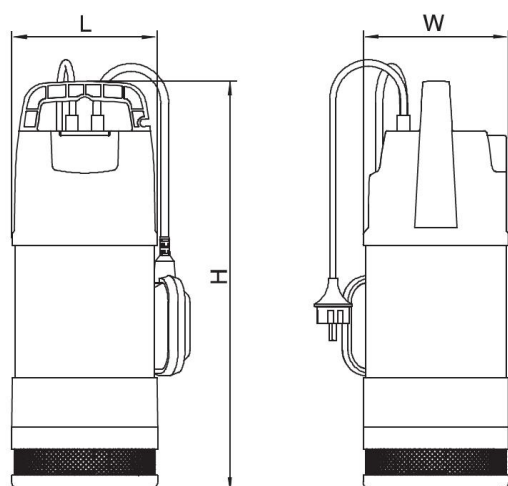

MODEL	DN	L	W	H
LKS-900S	1	163	163	455
LKS-1100S	1	163	163	479
LKS-1300S	1	163	163	503

Exploded view

No.	Type
1	Top cover
2	Terminal Box
3	Capacitor
4	Float switch
5	O-ring
6	Jacket
7	Rear cover
8	Rotor
9	Bearing
10	Stator
11	Stator casing
12	Mechanical seal
13	Front engine bearing support
14	Guide sleeve
15	Impeller
16	Diffuser
17	Clamping plate
18	Diffuser
19	Clamping plate
20	Strainer
21	Base

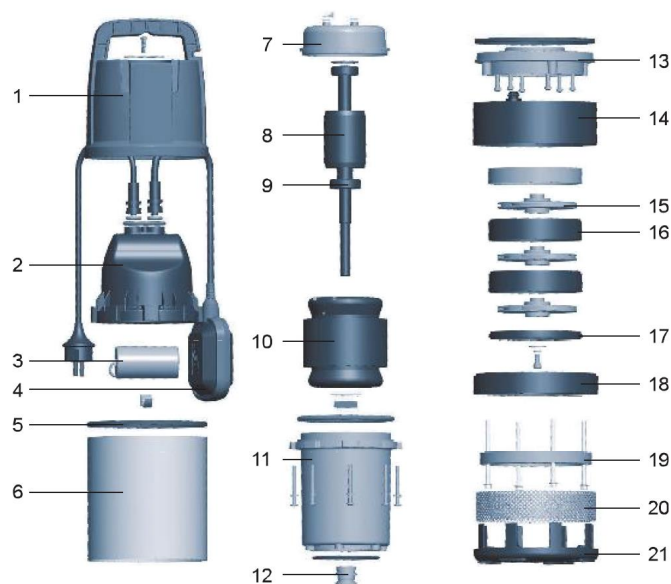

Packaging

MODEL	Weight (kg)	Length L (mm)	Width W (mm)	Height H (mm)
LKS-900S	11.2	488	250	210
LKS-1100S	12.3	510	250	210
LKS-1300S	13.2	535	250	210

