

EDH2 Horizontal multistage pump made entirely of stainless steel

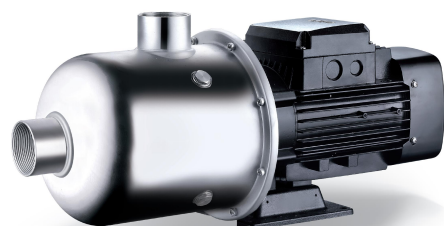

Application

- Water supply for tall buildings, pumping stations, overpressure
- Washing stations, heating water circulation, air conditioning water circulation, water treatment systems
- Ultrafiltration, reverse osmosis, distillation systems, municipal swimming pools
- Irrigation: sprinkling, drip
- Industry
- Fire fighting systems

Pompe

- Stainless steel shaft
- Max liquid temperature: +85°C
- Max suction height: 8 m
- Maximum operating pressure: 10 bars
- pH between 4 and 10

Moteur

- IE3 motor
- Protection class: IP55
- Insulation class: F
- Maximum ambient temperature: +40°
- Integrated thermal protection for single-phase versions
- Altitude: up to 1000 m

Identification codes

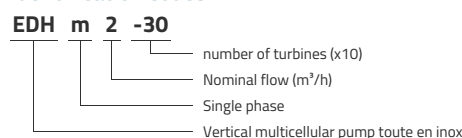

Technical data

MODEL	kW	Q (m ³ /h)	0.5	1	1.5	2	2.5	3	3.5	4
		Q (l/min)	8	17	25	33	42	50	58	67
EDHm2-20	0.37	16.7	16.2	15	14	11	10.6	8.8	6.5	
EDH2-20	0.37	16.7	16.2	15	14	11	10.6	8.8	6.5	
EDHm2-30	0.37	25.8	24.3	23.8	21.3	17	16.1	12.5	7.2	
EDH2-30	0.37	25.8	24.3	23.8	21.3	17	16.1	12.5	7.2	
EDHm2-40	0.55	34.8	34.1	33.2	30.7	23	22.9	18.4	12.6	
EDH2-40	0.55	34.8	34.1	33.2	30.7	23	22.9	18.4	12.6	
EDHm2-50	0.55	43.5	42.1	39.5	35.9	29	25.7	19.6	13.5	
EDH2-50	0.55	43.5	42.1	39.5	35.9	29	25.7	19.6	13.5	
EDHm2-60	0.75	50.8	49.2	45.6	41.5	35	30.4	23.4	14.3	
EDH2-60	0.75	50.8	49.2	45.6	41.5	35	30.4	23.4	14.3	

Dimensions

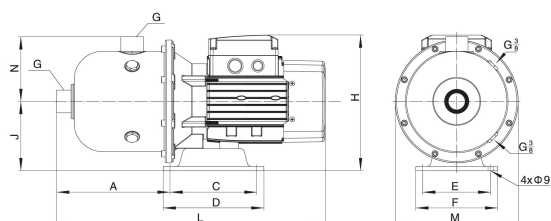

MODEL	L	A	C	D	E	F	G	H	J	M	N
EDHm2-20	427	180	138	160	108	130	1	216	110	195	103
EDH2-20	427	180	138	160	108	130	1	216	110	195	103
EDHm2-30	427	180	138	160	108	130	1	216	110	195	103
EDH2-30	427	180	138	160	108	130	1	216	110	195	103
EDHm2-40	427	180	138	160	108	130	1	216	110	195	103
EDH2-40	427	180	138	160	108	130	1	216	110	195	103
EDHm2-50	427	180	138	160	108	130	1	216	110	195	103
EDH2-50	427	180	138	160	108	130	1	216	110	195	103
EDHm2-60	427	180	138	160	108	130	1	216	110	195	103
EDH2-60	427	180	138	160	108	130	1	216	110	195	103

Hydraulic performance

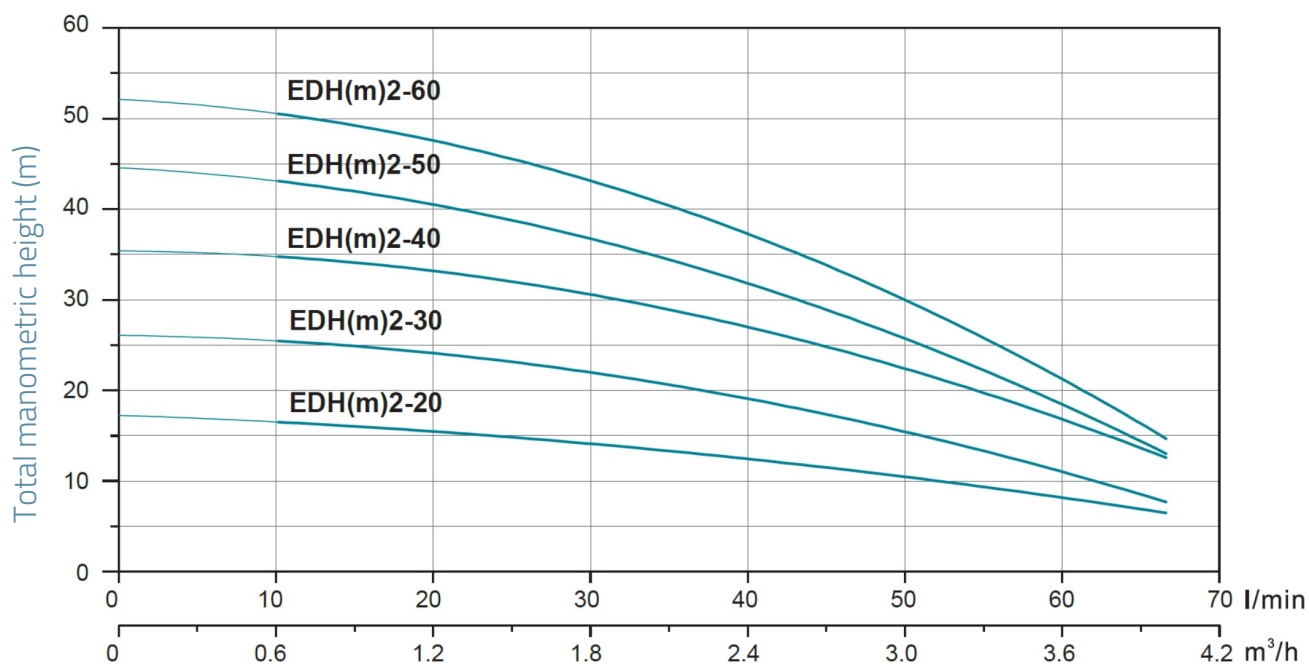

Exploded view

No.	Type	Materials
1	Pump body	AISI 304 stainless steel
2	Lantern	cast aluminum ZL102
3	Motor support	cast iron HT200
4	Stator	
5	Rotor	
6	Bearing	
7	Rear cover	cast aluminum ZL102
8	Fan	polypropylene
9	Fan cover	08F steel
10	Pump bottom	AISI 304 stainless steel
11	Mechanical seal	silicon carbide / graphite
12	Shim	AISI 304 stainless steel
13	Diffuser	AISI 304 stainless steel
14	Diffuser	AISI 304 stainless steel
15	Bearing	AISI 304 stainless steel
16	Impeller	AISI 304 stainless steel
17	Diffuser	AISI 304 stainless steel
18	Front plate	AISI 304 stainless steel
19	Spacer sleeve	AISI 304 stainless steel

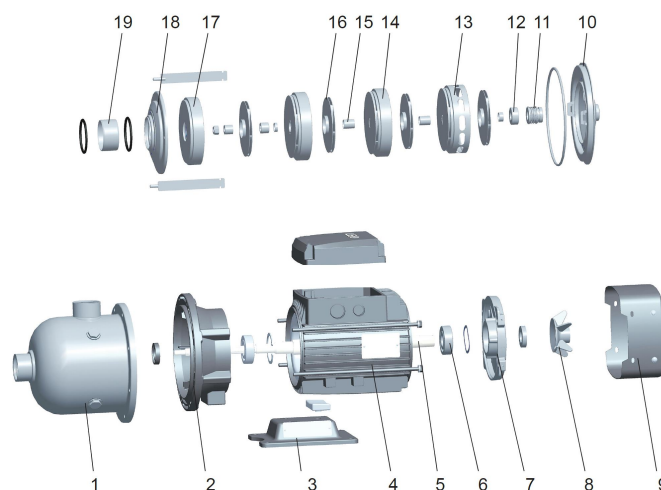

Packaging

MODEL	Weight (kg)	Length L (mm)	Width W (mm)	Height H (mm)
EDHm2-20	10.7	465	225	270
EDH2-20	10.7	465	225	270
EDHm2-30	11.1	465	225	270
EDH2-30	11.1	465	225	270
EDHm2-40	12.4	465	225	270
EDH2-40	12.4	465	225	270
EDHm2-50	12.8	465	225	270
EDH2-50	12.8	465	225	270
EDHm2-60	13.8	465	225	270
EDH2-60	13.8	465	225	270

