

# ECH20 Horizontal multistage stainless steel pump

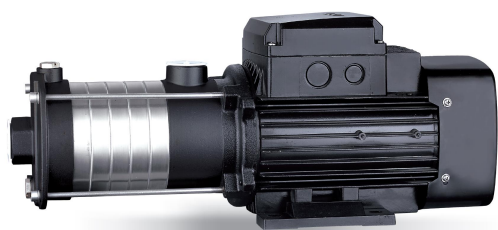

**ECH**

### Application

- Water supply for tall buildings, pumping stations, overpressure
- Washing stations, heating water circulation, air conditioning water circulation, water treatment systems
- Ultrafiltration, reverse osmosis, distillation systems, municipal swimming pools
- Irrigation: sprinkling, drip
- Industry
- Fire fighting systems

### Pompe

- Stainless steel shaft
- Max liquid temperature: +85 °C
- Max suction height: 8 m
- Maximum operating pressure: 5 bars
- pH between 4 and 10

### Moteur

- IE3 motor
- Protection class: IP55
- Insulation class: F
- Maximum ambient temperature: +40°
- Integrated thermal protection for single-phase versions
- Altitude: up to 1000 m

### Identification codes

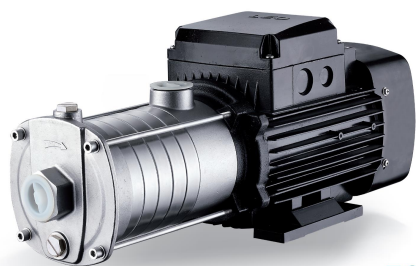
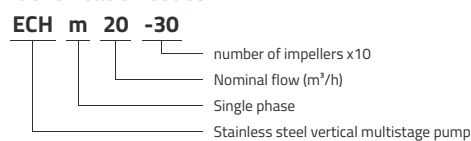

**ECHS**

## Technical data

MODEL	kW	Q (m <sup>3</sup> /h)				
		12	16	20	24	28
<b>ECHm20-10</b>	1.1	12.1	10.8	9.5	7.8	5.7
<b>ECH20-10</b>	1.1	12.1	10.8	9.5	7.8	5.7
<b>ECHm20-20</b>	2.2	26.1	24.4	22.4	19.8	17.2
<b>ECH20-20</b>	2.2	26.1	24.4	22.4	19.8	17.2
<b>ECH20-30</b>	4	39.9	38	35.5	31.4	26.9
<b>ECH20-40</b>	4	52.7	50.1	45.9	40.3	34

## Dimensions

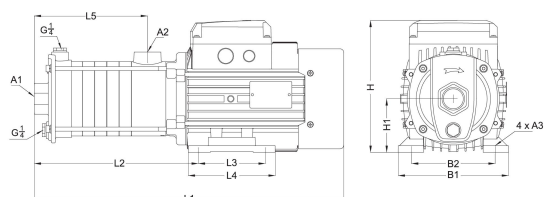

MODEL	L1	L2	L3	L4	L5	B1	B2	H	H1	A1	A2	A3
<b>ECHm20-10</b>	451	233.5	100	130	139.5	165	125	204.5	80	2	2	10
<b>ECH20-10</b>	451	233.5	100	130	139.5	165	125	204.5	80	2	2	10
<b>ECHm20-20</b>	510	222	125	150	139.5	180	140	217.5	90	2	2	10
<b>ECH20-20</b>	510	222	125	150	139.5	180	140	217.5	90	2	2	10
<b>ECH20-30</b>	570.5	291	140	180	184.5	205	160	224.5	100	2	2	12
<b>ECH20-40</b>	616	336.5	140	180	230	205	160	224.5	100	2	2	12

## Hydraulic performance

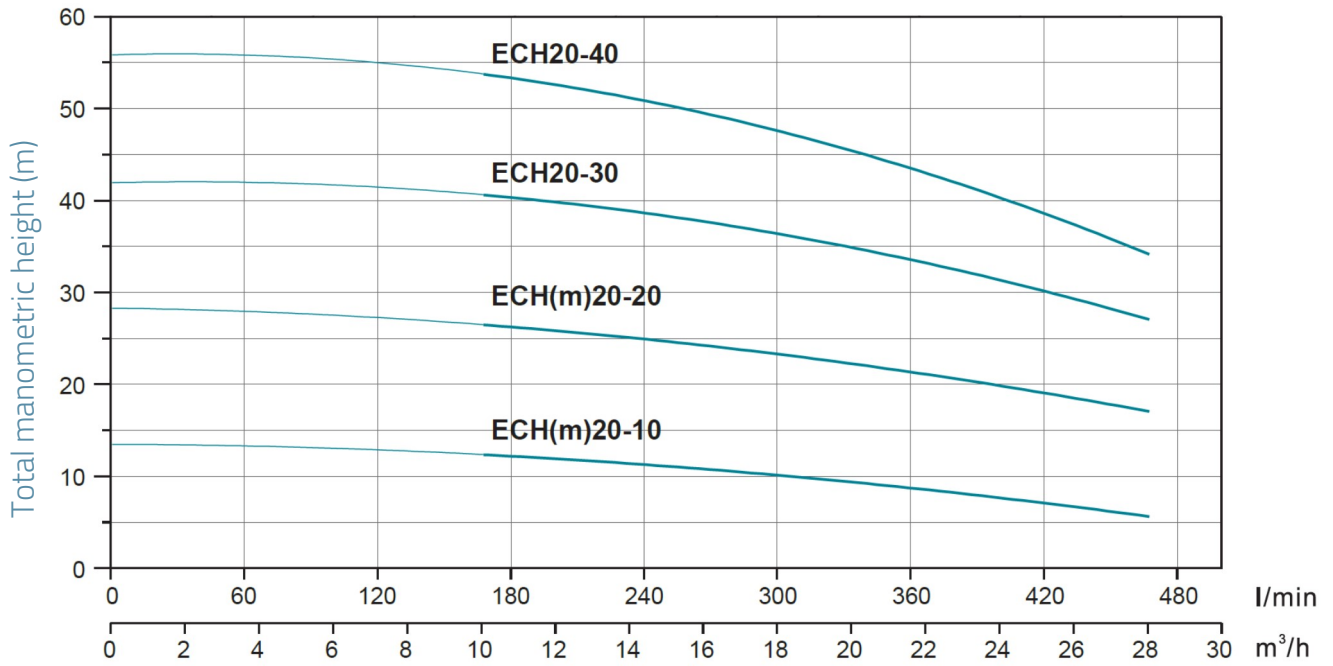

## Exploded view

No.	Type	Materials
1	Fan cover	O8F steel
2	Fan	polypropylene
3	Rear cover	cast aluminum ZL102
4	Rotor	
5	Bearing	
6	Electric box cover	cast aluminum ZL102
7	Stator	
8	Lantern	cast iron HT200
9	Outlet diffuser	cast iron HT200
10	Mechanical seal	silicon carbide / graphite
11	Shim	AISI 304 stainless steel
12	Diffuser	AISI 304 stainless steel
13	Bearing	AISI 304 stainless steel
14	Impeller	AISI 304 stainless steel
15	Front cover	cast iron HT200

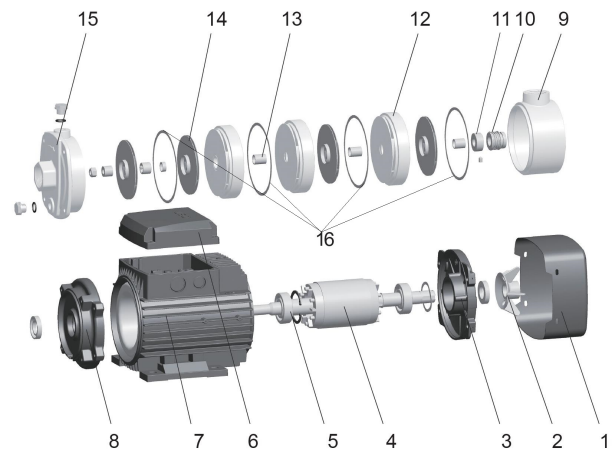

## Packaging

MODEL	Weight (kg)	Length L (mm)	Width W (mm)	Height H (mm)
ECHm20-10	22.7	503	235	268
ECH20-10	22.7	503	235	268
ECHm20-20	30.3	557	245	283
ECH20-20	30.3	557	245	283
ECH20-30	38.9	687	245	290
ECH20-40	39.4	687	245	290

