

ACmC2 Centrifugal cast iron pump

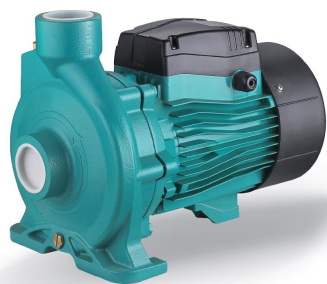
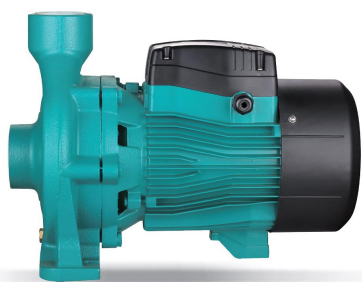

Application

- Transfer of clear water or other liquids chemically and physically comparable to water
- Suitable for industrial use and water supply, overpressure for fire system, garden irrigation, air conditioning system, circulation and overpressure, etc ...

Pompe

- Special anti-rust treatment (cataphoresis) for the cast iron pump body and the lantern
- AISI 304 stainless steel shaft
- Maximum liquid temperature: +40°C
- Maximum suction height: 8 m

Moteur

- Integrated thermal protection for single-phase motors
- Insulation class: F
- Protection class: IPX4
- Maximum ambient temperature: +40°C

Identification codes

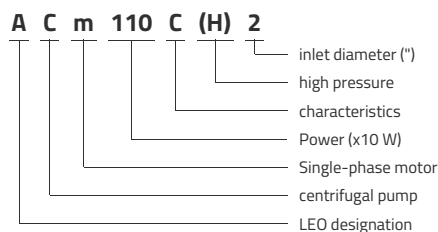

Technical data

MODEL	kW	Q (m³/h)	0	6	9	12	15	18	24	27	30	36	42	48	54
		Q (l/min)	0	100	150	200	250	300	400	450	500	600	700	800	900
ACm220CH2	2.2		31	30	29.5	28.5	27.5	26	21.5	18.5					
AC220CH2	2.2		31	30	29.5	28.5	27.5	26	21.5	18.5					
ACm300C2	3		30	29.5	29	28.5	28	27	25	23.5	22	19.5	15.5	11.5	
AC300C2	3		30	29.5	29	28.5	28	27	25	23.5	22	19.5	15.5	11.5	
ACm300CH2	3		38	37.5	37	36	34.5	33	28.5	25.5					
AC300CH2	3		38	37.5	37	36	34.5	33	28.5	25.5					
ACm400C2	4		39	38.5	38	37.5	37	36	34	32.5	31	28	24	18.5	13
AC400C2	4		39	38.5	38	37.5	37	36	34	32.5	31	28	24	18.5	13
ACm400CH2	4		49	48	47	46	45	43.5	39.5	37					
AC400CH2	4		49	48	47	46	45	43.5	39.5	37					
AC550C2	5.5		46.5	45.5	45	44.5	43.5	42.5	40	38.5	37	33	28	22	15
AC550CH2	5.5		54	52.5	52	51	50	49	46	44	42				
AC750C2	7.5		56.5	55	55	54.5	53.5	52.5	50	48.5	46.5	42	36.5	30.5	20
AC750C4	7.5		52.5	52	52	51.5	51	50.5	48	46.5	44.5	40	35.5	30.5	24

Dimensions

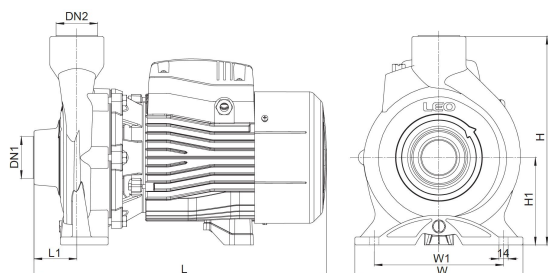

MODEL	DN1	DN2	L	W	H	L1	W1	H1
ACm220CH2	2	2	444	255	315	65	186	132
AC220CH2	2	2	444	255	315	65	186	132
ACm300C2	2	2	444	255	315	65	186	132
AC300C2	2	2	444	255	315	65	186	132
ACm300CH2	2	2	444	255	315	65	186	132
AC300CH2	2	2	444	255	315	65	186	132
ACm400C2	2	2	496.5	280	326	70	195	136
AC400C2	2	2	496.5	280	326	70	195	136
ACm400CH2	2	2	496.5	280	326	70	195	136
AC400CH2	2	2	496.5	280	326	70	195	136
AC550C2	2	2	496.5	280	326	70	195	136
AC550CH2	2	2	496.5	280	326	70	195	136
AC750C2	2	2	515	290	360	85	216	150
AC750C4	4	3	525	290	360	85	216	150

Hydraulic performance

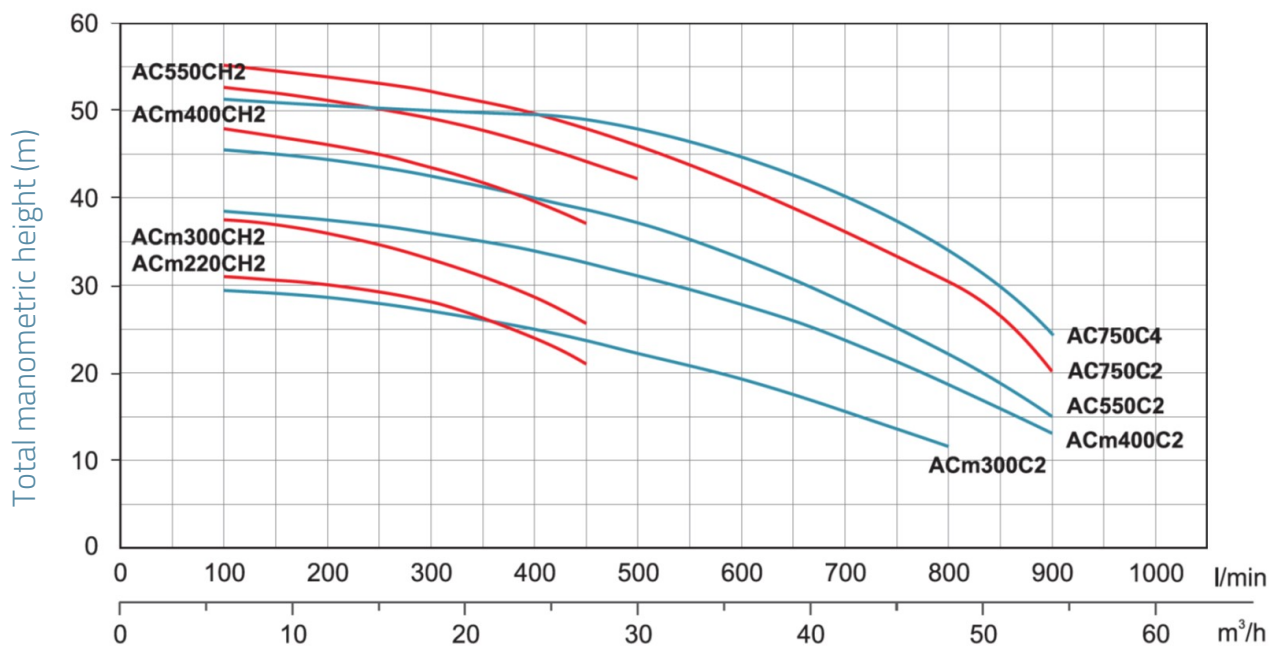

Exploded view

No.	Type	Materials
1	Pump body	cast iron HT200
2	Impeller	AISI 304 stainless steel
3	Mechanical seal	carbon / ceramic
4	Pump bottom	cast iron HT200
5	Oil seal	
6	Lantern	cast iron HT200
7	Bearing	
8	Rotor	
9	Fan cover	polypropylene
10	Fan	polypropylene
11	Rear cover	cast aluminum ZL102
12	Stator	
13	Capacitor	
14	Electric box cover	ABS
15	O-ring	nitrile rubber (NBR)

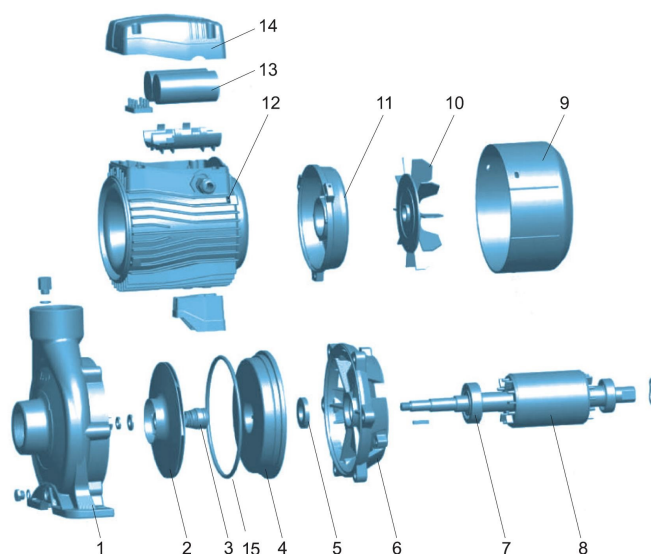

Packaging

MODEL	Weight (kg)	Length L (mm)	Width W (mm)	Height H (mm)
ACm220CH2	390	507	304	372
AC220CH2	390	507	304	372
ACm300C2	41.4	507	304	372
AC300C2	41.4	507	304	372
ACm300CH2	41.8	507	304	372
AC300CH2	41.8	507	304	372
ACm400C2	57.5	562	328	372
AC400C2	57.5	562	328	372
ACm400CH2	56.5	562	328	383
AC400CH2	56.5	562	328	383
AC550C2	55.5	562	328	383
AC550CH2	57.1	562	328	383
AC750C2	62	587	338	417
AC750C4	63.7	587	338	417

